



MOTOROLA

MTR2000™

**Base Station, Repeater and Receiver
For Analog Conventional,
and Trunking Systems**



**Installation and Operation
Manual**

68P81096E20-N

COMPUTER SOFTWARE COPYRIGHTS

The Motorola products described in this instructions manual may include copyrighted Motorola computer programs stored in semiconductor memories or other media. Laws in the United States and other countries preserve for Motorola certain exclusive rights for copyrighted computer programs. Including the exclusive right to copy or reproduce in any form the copyrighted computer program. Accordingly, any copyrighted Motorola computer programs contained in the Motorola products described in this Instruction manual may not be copied or reproduced in any manner without the express written permission of Motorola. Furthermore, the purchase of Motorola products shall not be deemed to grant either directly or by implication, estoppel or otherwise, any license under the copyrights, patents or patent applications of Motorola, except for the normal nonexclusive, royalty free license to use that arises by operation of law in the sale of a product.

COMMERCIAL WARRANTY (U.S. Only)

Motorola radio communications products are warranted to be free from defects in material and workmanship for a period of ONE (1) YEAR, (except for crystals and channel elements which are warranted for a period of ten (10) years from the date of shipment. Parts, including crystals and channel elements, will be replaced and labor will be provided free of charge for the full warranty period, from the date of shipment. Thereafter purchaser must pay for the labor involved in repairing the product and replacing the parts at the prevailing rates together with any transportation charges to or from the place where warranty service is provided. This express warranty is extended by Motorola Communications and Electronics Inc., 1301 E. Algonquin Road, Schaumburg, Illinois 60196, to the original purchaser only, and only to those purchasing for purpose of leasing or solely for commercial, industrial, or government use.

THIS WARRANTY IS GIVEN IN LIEU OF ALL OTHER WARRANTIES EXPRESSED OR IMPLIED WHICH ARE SPECIFICALLY EXCLUDED, INCLUDING WARRANTIES OF MERCHANTABILITY OR FITNESS FOR A PARTICULAR PURPOSE. IN NO EVENT SHALL MOTOROLA BE LIABLE FOR INCIDENTAL OR CONSEQUENTIAL DAMAGES TO THE FULL EXTENT SUCH MAY BE DISCLAIMED BY LAW.

In the event of a defect, malfunction or failure to conform to specifications established by seller, or if appropriate, to specifications accepted by Seller in writing, during the period shown, Motorola, at its option, will either repair or replace the product or refund the purchase price thereof, and such action on the part of Motorola shall be the full extent of Motorola's liability hereunder.

This warranty is void if:

- a. the product is used in other than its normal and customary manner;
- b. the product has been subject to misuse, accident, neglect or damage;
- c. unauthorized alterations or repairs have been made, or unapproved parts used in the equipment.

This warranty extends only to individual products, batteries are excluded. Because each radio system is unique, Motorola disclaims liability for range, coverage, or operation of the system as a whole under this warranty except by a separate written agreement signed by an officer of Motorola.

LICENSED PROGRAMS -- Motorola software provided in connection with this order is warranted to be free from reproducible defects for a period of one (1) year. All material and labor to repair any such defects will be provided free of charge for the full warranty period, and SUBJECT TO THE DISCLAIMER IN BOLD FACE TYPE.

Non-Motorola manufactured products are excluded from this warranty, but subject to the warranty provided by their manufacturers, a copy of which will be supplied to you on specific written request.

In order to obtain performance of this warranty, purchaser must contact its Motorola salesperson or Motorola at the address shown in the second paragraph, attention Quality Assurance Department.

FCC INTERFERENCE WARNING

The FCC requires that manuals pertaining to Class A and Class B computing devices must contain warnings about possible interference with local residential radio and TV reception. This warning reads as follows:

NOTE: The equipment has been tested and found to comply with the limits for a Class B digital device, pursuant to Part 15 of the FCC Rules. These limits are designed to provide reasonable protection against harmful interference when the equipment is operated in a commercial or residential environment. This equipment generates, uses, and can radiate radio frequency energy and, if not installed and used in accordance with its instruction manual, may cause harmful interference to radio communication.

ELECTROMAGNETIC COMPATIBILITY

This product conforms with the protection requirements of Council Directive 89/336/EEC of 3rd May 1989 (EMC) on the approximation of the laws of the Member States relating to electromagnetic compatibility.

ENVIRONMENTAL INFORMATION

Material Content

The material content of the MTR2000 is 16% of the product it replaces.

The following table provides a rough estimate of the material content of the station. The actual percentages vary in relation to the station configuration. The power supply is not included in the percentage of weights since the end-of-life value is dependent on the model of supply used in the station.

Most of the Material categories are self explanatory. Copper bearing materials:

- include any material that contains copper.
- primarily consist of circuit boards.
- exclude cables (separate Material category).

Material	% by weight
Aluminum	92%
Steel	2%
Copper Bearing	4%
Cable	1%
Polycarbonate	1%

Beryllium Oxide has been used in the power amplifier. Beryllium Oxide should not be subjected to any process which will generate dust.

Features

Over 92% of the station is made of aluminum, one of the most recycled materials commonly available today. In addition, the aluminum used in the station consists of 90-95% recycled content.

Plastic use has been minimized since the market for recycled engineering plastics is limited. The plastic which has been used for the front panel is a relatively clean and pure resin.

Disposal of your Electronic and Electric Equipment

Please do not dispose of Electronic and Electric Equipment or Electronic and Electric Accessories with your household waste. In some countries or regions, collection systems have been set up to handle waste of electrical and electronic equipment.

In European Union countries, please contact your local equipment supplier representative or service center for information about the waste collection system in your country.

Disposal Guideline

The following symbol on a Motorola product indicates that the product should not be disposed of with household waste.

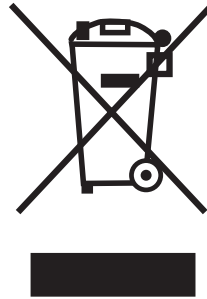

FOREWORD

Scope of Manual

This manual is intended for use by experienced technicians familiar with similar types of equipment.

It provides information which allows installation personnel to unpack, mechanically install, electrically connect, and verify operation of the station.

The information in this manual is current as of the printing date. Changes which occur after the printing date are incorporated by Manual Revisions (SMR). These SMRs are added to the manuals as the engineering changes are incorporated into the equipment.

Documentation Conventions

Documentation conventions are used in this manual to highlight certain information.

The area to the left of the text column contains key words and graphic symbols which allow the reader to quickly identify desired information.

The following text highlight symbols are used:



A note symbol indicates important information that helps improve the described function.



A caution symbol indicates a potential problem, unless the proper actions are taken. A caution also explains how to avoid the problem.



A WARNING symbol indicates the potential for personal injury or serious system degradation unless the proper actions are taken. A WARNING also explains how to avoid the problem.



An IMPORTANT symbol indicates the potential for damaging the station unless the proper actions are taken. An IMPORTANT note also explains how to avoid the problem.

GENERAL SAFETY INFORMATION

The United States Department of Labor, through the provisions of the Occupational Safety and Health Act of 1970 (OSHA), has established an electromagnetic energy safety standard which applies to the use of this equipment. Proper use of this radio will result in exposure below the OSHA limit. The following precautions are recommended:

- DO NOT operate the transmitter of a mobile radio when someone outside the vehicle is within two feet (0.6 meter) of the antenna.
- DO NOT operate the transmitter of a fixed radio (base station, microwave and rural telephone rf equipment) or marine radio when someone is within two feet (0.6 meter) of the antenna.
- DO NOT operate the transmitter of any radio unless all rf connectors are secure and any open connectors are properly terminated.

In addition:

- DO NOT operate this equipment near electrical blasting caps or in an explosive atmosphere.
- All equipment must be properly grounded according to Motorola installation instructions for safe operation.
- All equipment should be serviced only by a qualified technician.
- An operating license may be required to operate this station.

Refer to the appropriate section of the product service manual for additional pertinent safety information.



Some station components can become extremely hot during station operation. Turn off all power to the station, and wait until sufficiently cool before touching the station.



MTR2000™

Station, Repeater and Receiver For Analog Conventional, and Trunking Systems

Table of Contents

Scope of Manual ix
 Documentation Conventions ix
 General Safety Information..... x

DESCRIPTION

DESCRIPTION	68P81096E36
INTRODUCTION	1
Flexible Mechanical Design	1
Electrical Design	2
Trunking Capability	2
Summary of Operating Features	3

, MOTOROLA, MTR2000, Spectra-TAC, DigiTAC and Private Line are trademarks of Motorola Inc.
 TORX is a trademark of Camcar Division of Textron Inc.

STATION COMPONENTS	4
FUNCTIONAL THEORY OF OPERATION	5
Transmitter Circuitry Operation	5
Receiver Circuitry Operation	7
Station Control Module Operation	8
Wireline Interface Board Operation	9
Auxiliary I/O Board Operation	10
Power Supply Module Operation	11

INSTALLATION

INSTALLATION

68P81096E37

PRE-INSTALLATION CONSIDERATIONS	1
Installation Overview	1
Environmental Conditions at Intended Installation Site	2
Equipment Ventilation	3
AC Input Power Requirements	4
Equipment Mounting Methods	5
Floor-mount Cabinet	6
Modular Racks	8
Site Grounding and Lightning Protection	10
Site Grounding Lightning Protection Recommendations	10
Equipment Grounding Guidelines	10
Recommended Tools and Equipment	11
Equipment Unpacking and Inspection	11
Cabinet Unpacking	11

MECHANICAL INSTALLATION	12
Unpacking Equipment	12
Introduction	12
Unpacking Stations	12
Front Panel – Removal and Replacement	12
Unpacking Floor-mount Cabinets	13
Mounting Procedures	15
Introduction	15
Installing Racks	15
Mounting Floor-mount Cabinets	16
Transferring Equipment from Shipping Container to Rack or Cabinet	16
Installing Slide Rail Assembly in a Motorola Cabinet	17
Installing Slide Rail Assembly in a Non-Motorola Cabinet	19
BOARD CONFIGURATION	21
4-Wire Wireline Interface Board	21
4-Wire Euro Wireline Interface Board	21
Auxiliary I/O Board	23
ELECTRICAL CONNECTIONS	26
Power Supply Connections	28
AC Input Power Connection	28
Ground Connection	29
DC Input Power Connection	29
Battery Connection	29
RF Antenna Connections	31
System Cable Connections	32
Telephone Line Connections	37
Introduction	38
Telephone Line Specifications	39
Location of Telephone Line Connections	40
System Type vs. Wireline Circuit	41
Station Maintenance Connections	42
POST INSTALLATION CHECKLIST	43
Applying Power	43
Verifying Proper Operation	44
Front Panel LEDs	44
Listening For Audible Alarms	46
Exercising Radio Operation	46

OPTIMIZATION	47
Optimizing Tasks	47
Copying Station Codeplug Data To a PC-compatible Computer	47
INSTALLING STATION HARDWARE OPTIONS	48

STATION OPERATION

STATION OPERATION

68P81096E38

DESCRIPTION	1
LED Indicators	2
External Device Connections	3
Service Connections	4

List of Figures

DESCRIPTION

DESCRIPTION	68P81096E36
Figure 1. MTR2000 Station	1
Figure 2. MTR2000 Station Components	4
Figure 3. MTR2000 Station Functional Block Diagram (Sheet 1 of 2)	14
Figure 3. MTR2000 Station Functional Block Diagram (Sheet 2 of 2)	15

INSTALLATION

INSTALLATION	68P81096E37
Figure 1. Floor-mount Cabinet – Dimensions and Clearances	7
Figure 2. Modular Rack – Dimensions and Clearances	9
Figure 4. Unpacking Procedures - Floor-mount Cabinets	14
Figure 5. Slide Rail Installation; Option X968AA (Left Side Shown)	18
Figure 6. Slide Rail Installation; Option X346AB (Left Side Shown)	20
Figure 7. CLN1203 Wireline Interface Board Jumper Settings	21
Figure 8. CLN1204 Wireline Interface Board Jumper Settings	22
Figure 9. CLN1206 Auxiliary I/O Board Jumpers	23
Figure 10. Location of External Connectors at Rear of Station	27
Figure 11. Making Connections to Storage Battery	30

STATION OPERATION

STATION OPERATION	68P81096E38
Figure 1. Front Panel LEDs.....	2
Figure 2. SCM Connectors	4

List of Tables

INSTALLATION

INSTALLATION

68P81096E37

Table 1.	Configuring Input GPI_14 Function	24
Table 2.	Configuring Output GPO_14 Function	24
Table 3.	Configuring Output GPO_15 Function	25
Table 4.	System Connector – Commonly Used Pins	33
Table 5.	Summary of Auxiliary Inputs/Outputs at the System Connector	34
Table 6.	J5 SYSTEM CONNECTOR, Row A Pins	35
Table 7.	J5 SYSTEM CONNECTOR, Row B Pins	36
Table 8.	J5 SYSTEM CONNECTOR, Row C Pins	37
Table 9.	Type 5 and “3002” Phone Line Specifications	39
Table 10.	Wireline Connector Line Pair Assignments	40
Table 11.	System Types vs. Wireline Circuit Matrix	41
Table 12.	Station Maintenance Connections on the SCM	42

1 INTRODUCTION

The Motorola MTR2000 Base Station/Repeater provides analog conventional and trunking capabilities in a reliable, software-controlled design. An innovative modular design and microprocessor-controlled Station Control Module (SCM) allows for superior station flexibility and simplified system upgrades.

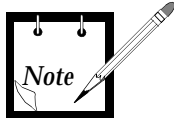

All of the features described in this manual may not be currently supported. Refer to the “Summary of Operating Features” section for a list of standard features, optional features, and planned future features.

Flexible Mechanical Design

All elements of the station are designed for EIA 48.3 cm (19") rack mounting, allowing the equipment to be mounted in standard telephone-style equipment racks, or various sizes of Motorola cabinets. Figure 1 shows a typical 40W station.



Figure 1. MTR2000 Station

Electrical Design

Transmitter Circuitry

The station transmitter circuitry is designed for continuous duty operation and may be operated at full rated power. Output power is continually monitored by an internal directional coupler. The forward power voltage from the coupler feeds a power control loop which continually adjusts and maintains the desired output power. All adjustments are electronic, including deviation and output power.

Receiver Circuitry

The station receiver circuitry features multiple bandwidth (12.5kHz, 20kHz, 25kHz, and 30kHz) capability. Injection signals for the first and second mixers are generated by frequency synthesizer circuitry electronically controlled by the Station Control Module. All receive signals (analog) are detected and digitized before being sent to the Station Control Module, providing improved, consistent audio quality throughout the coverage area.

Station Control Module

The Station Control Module is microprocessor-based and features extensive use of ASIC and digital signal processing technology. The module serves as the main controller for the station, providing signal processing and operational control for the station modules.

Wireline Circuitry

The station wireline circuitry options provide a wide variety of telephone interfaces and control mechanisms such as Tone Control. Telephone line connections are easily made to the wireline circuitry via connectors on the rear of the station.

Trunking Capability

When equipped for trunking capability, the station can operate in Motorola's Smartnet™ or the most advanced wide-area trunking system – *SmartZone*. The station can operate as a remote voice channel or control channel repeater. The station interfaces to a Trunking Central Controller (TCC) which provides the call processing and channel assignment tasks.

Summary of Operating Features

Standard Features

The following are a few of the standard features:

- FRU maintenance philosophy (reducing down time).
- Easily programmed via Radio Service Software (RSS).
- Extensive Self-Test Diagnostics and Alarm Reporting through RSS.
- Expansion and upgrades performed by module replacement.
- Highly reliable and accurate continuous duty transmitter circuitry.
- Compatible (with appropriate options) with conventional analog signaling.
- Wide operating temperature range: -30°C to +60°C (-22°F to +140°F).
- Battery Backup Connector – allows connection to battery backup system which automatically reverts to battery backup operation in the event of ac power failure.
- RA/RT
- Wide voltage supply range (AC or DC), with no setup configuration.

Optional Features

The following are some of the leading optional features for the station:

- Double Circulator Option – provides additional isolation and intermodulation protection for rf-congested transmitter sites (not available on 350 MHz stations).
- Microprocessor Radio Telephone Interconnect (MRTI) – allows connection of conventional station to the telephone network.
- Trunking – allows trunking repeater to operate as part of a *Smartnet* or *Smart-Zone* system; through Auxiliary I/O board (CLN1206).
- Wildcard Input/Output; through Auxiliary I/O board (CLN1206).
- Main Standby; through Auxiliary I/O board (CLN1206).
- Multi-coded Squelch Interface; through Zetron Model 38 Repeater Panel.
- Console Priority Interface; through 8-Wire Wireline Interface Board (CLN1205).
- Auxiliary Input/Output for conventional operation; through Auxiliary I/O board (CLN1206).

Features Not Offered

Please disregard any references to the following **items** since they are **not available for the MTR2000**:

- DC Remote control for the 4-wire Wireline Interface Board, CLN1203.
- Second Receiver configuration of the MTR2000.

2

STATION COMPONENTS

Figure 2 shows the modules and components that comprise a station.

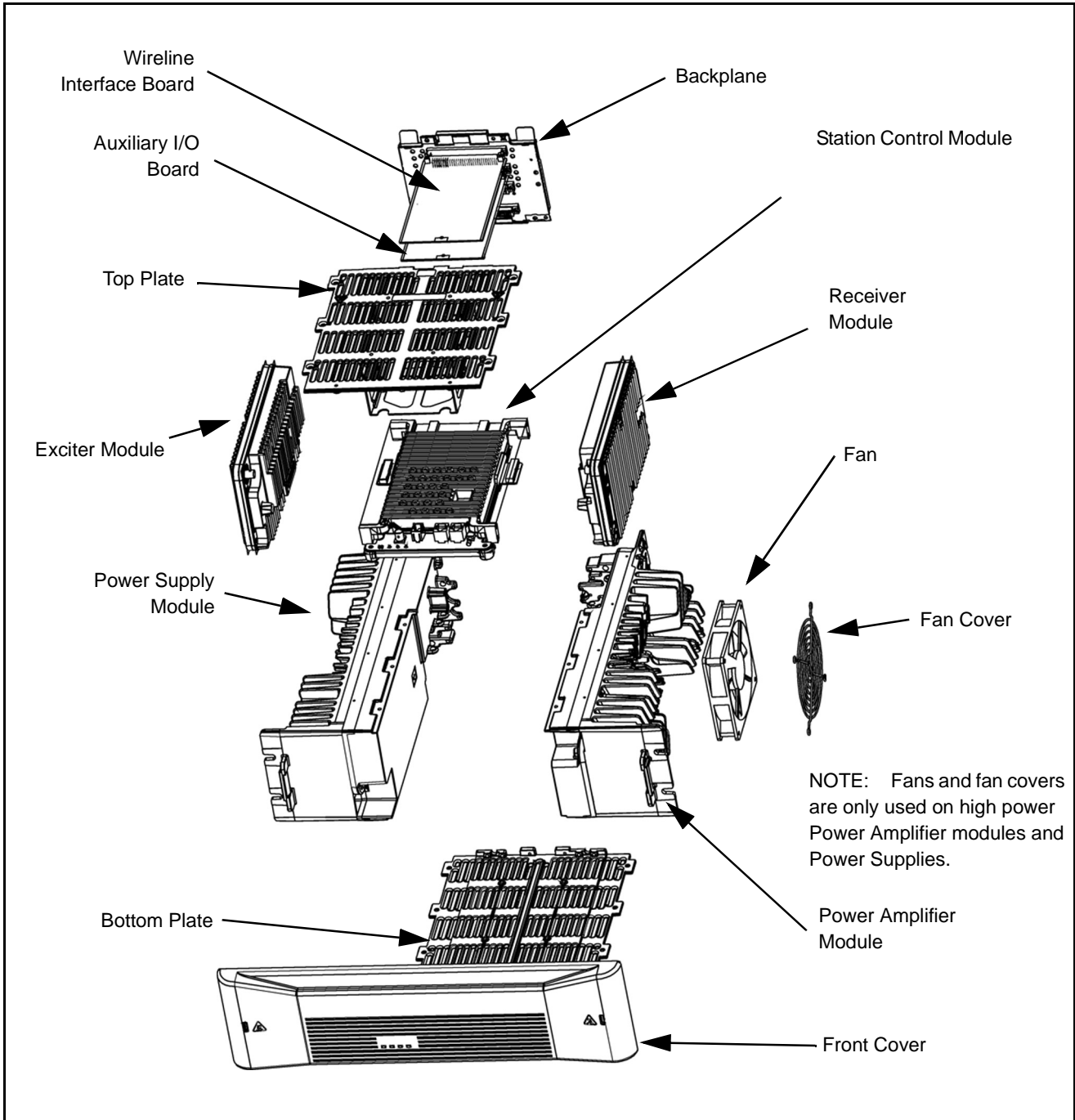

Figure 2. MTR2000 Station Components

3**FUNCTIONAL THEORY OF OPERATION**

The following functional theory of operation provides an overview of the station circuitry. For a more thorough functional description of a particular module, refer to the STATION MODULES section of the appropriate band-specific Instruction Manual. The block diagram in Figure 3 supports the following functional theory of operation.

Transmitter Circuitry Operation**Introduction**

The Transmitter Circuitry comprises two modules, the Exciter Module and the Power Amplifier (PA) Module. These modules combine to generate, modulate, and amplify the rf signal which is transmitted via the site transmit antenna. Modulation sensitivity and power output are adjusted electronically for each channel (through the Radio Service Software), under the direct control of the Station Control Module (SCM).

Exciter Module Operation

The Exciter Module, which interfaces directly to the SCM, generates a modulated rf signal at the desired transmit frequency and sends this signal to the PA for amplification. The circuitry operates as follows.

The transmit synthesizer and VCO (voltage-controlled oscillator) circuitry on the Exciter Module accept frequency programming data from the SCM (via the SPI bus) and generate an rf carrier at the specified frequency. The VCO is directly modulated by transmit audio/data from the SCM. The resulting modulated rf signal (at a level of approximately +12 dBm) is then fed to the PA.

Power Amplifier Module Operation

The PA modules are designed for continuous-duty operation across all bands and power levels. The actual circuit stages employed in a PA depend on the specific frequency band, power output level and intermodulation requirements. All PA modules contain an Intermediate Power Amplifier (IPA) at the input, a low-pass filter/directional coupler at the output, and diagnostic and power control circuitry.

High power (100 W) PA modules employ a single internal circulator to protect the PA from transmitter intermodulation and antenna mismatch (VSWR). The low power 30 W PA module employs two internal circulators. All PA stages and circulators are broad-band devices and require no tuning to operate at the station site.

The modulated rf signal from the Exciter Module is input to the IPA in the PA Module, and amplified to within a range of 0 to 10 W (depending on power control signals from the SCM). In PA Modules operating below 600 MHz, the rf signal is fed to either a Butterfly Module (30W/40W PA models) or a Dual Device Module (DDM – 100W PA models). In PA Modules operating above 600 MHz, a 15 W driver is introduced

between the Pre-driver stage and the Final Module. The gain of the Pre-driver stage is controlled by a power control voltage which is derived from power control signals (from the SCM) and high VSWR/thermal protection circuitry on the PA output board.

A combination of hardware and software controls are used to regulate the power output level. To set the power and current limits, the SCM provides software control through a D/A converter connected to the SPI bus. This control relies on various monitored PA signals which are fed back to the SCM via an A/D converter (also connected to the SPI bus).

The directional coupler is essentially a calibrated wattmeter which feeds a dc voltage proportional to the output power to the power control circuitry to serve as the feedback signal in the power control loop. Under normal operating conditions, the power control circuitry compares this dc voltage from the directional coupler to a reference voltage from the D/A converter which represents the desired output power. Based on the comparison, a power control voltage is generated to control the output power from the PA Module.

The modulated rf signal is amplified by the Driver/Final Module and is output to the site transmit antenna via a circulator and a harmonic filter/coupler. During excessive output VSWR, the ratio of the forward and reflected voltages from the directional coupler may be used to reduce, or turn off, the transmitter power. Additional circuitry is also provided to reduce output power during excessive current drain and high temperature conditions, and to control the fan used in high power PA Modules.

Receiver Circuitry Operation

Introduction

The Receiver Circuitry accepts receive rf signals from the site receive antenna, performs filtering and dual conversion, and outputs a digitized receive signal to the Station Control Module. The receiver module utilized may have either an internal varactor-tuned preselector filter, or an external metal preselector filter.

Receiver Module Operation

The receive signal is input from the site receive antenna to the receiver module, or to an external preselector filter (a separate assembly attached to the rear of the station which provides highly selective bandpass filtering). The signal is fed through a low-pass filter, varactor-tuned preselector (if external preselector is not used), rf amplifier and image filter to the rf input of the first mixer. The filtered signal is mixed with an injection signal generated by the receive synthesizer/VCO, resulting in a first i-f (intermediate frequency) signal. The injection signal frequency is determined by frequency programming data from the Station Control Module via the SPI bus. The specific frequency of the first i-f depends on the frequency band of the station.

The first i-f signal is filtered and input to a custom receiver IC. This component contains circuitry for generating the second injection signal, mixing down the first i-f to 450 KHz, amplification and A/D (analog-to-digital) conversion of the second i-f signal, resulting in a digitized receive signal. This signal is fed as differential data to the Station Control Module.

Station Control Module Operation

Introduction

The Station Control Module (SCM) is the microprocessor-based controller for the station. Major components include an MC68356 microprocessor, which combines a 68302 Integrated Multiprotocol Processor (IMP) with a 56002 Digital Signal Processor (DSP), a DSP ASIC device, and several Codec filter devices.

Station Control Module Operation

The MC68356 forms the heart of the SCM. The 68302 portion is the Host Microprocessor (μ P), which serves as the controller for the SCM and operates from station software stored in FLASH memory. This software determines the system capabilities of the station. The Host μ P communicates with the station modules and the SCM circuitry via address and data buses, three SCI (Serial Communication Interface) ports, and an SPI bus.

The DSP portion of the MC68356, with the support of the DSP ASIC, perform the necessary digital processing for the station audio and data signals. The DSP circuitry interfaces with the Receiver Module (receive audio), the Exciter Module (VCO modulation signal), the Wireline Interface Board (wireline audio), and external audio devices (microphone and speaker).

The 2.1 MHz Reference Oscillator generates the reference signal used by the Receiver and Exciter Modules.

Wireline Interface Board Operation

Introduction

The Wireline Interface Board (WIB) serves as the interface between the customer analog telephone lines and the serial data signals of the station. WIBs are offered to handle 2-wire, 4-wire and 8-wire configurations. In general, the WIB processes and routes all wireline audio signals between the station and the landline equipment (such as consoles, modems, etc.). Landline-to-station and station-to-landline audio signals are connected to the WIB via copper pairs at the rear of the station.

Wireline Interface Board Operation

The WIB contains a PCM Codec-filter device to perform the audio digitization and reconstruction, as well as the band-limiting and smoothing required by PCM systems. Analog signals are routed as follows:

- Inbound analog signals are converted to digital signals and routed to the SCM as wireline transmit data (WL TxD).
- Outbound PCM data signals are converted to analog signals and routed to the Line 2 output.
- A latch receives control signals from the SCM (via the SPI bus) to control the gating of the audio signals.



For a list of the actual features supported, refer to the “Summary of Operating Features” on page 3, or the MTR2000 System Planner.

Auxiliary I/O Board Operation

Introduction

The Auxiliary I/O Board serves as the interface between the customer auxiliary equipment and the Station Control Module (SCM). In general, the Auxiliary I/O Board routes all auxiliary equipment control signals between the SCM and the auxiliary equipment (e.g., a trunking controller).

Auxiliary I/O Board Operation

The Auxiliary I/O Board contains SPI Input Buffers and associated circuitry which provides an input signal path from auxiliary equipment to the station SCM.

The input circuitry supports 16 general purpose inputs:

- 14 are transistor buffered inputs; 16V maximum, 10k Ω
- 2 are opto isolated inputs; 60mA forward current, 3V dropout voltage, 2kV isolation.

The Auxiliary I/O Board contains SPI Output Latches and associated circuitry which provides an output signal path from the station SCM to auxiliary equipment.

The output circuitry supports 16 general purpose outputs:

- 14 are open collector transistor outputs; maximum 40V, 100mA sink current
- 2 are dry contact outputs (relay); maximum 250V, 1A)

Not all inputs and outputs are supported, see Table 4, on page 33 through Table 8, on page 37.

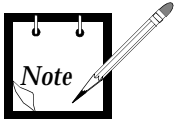

Power Supply Module Operation

Power Supply Modules are offered to handle:

- ac or dc input power
- low power (250 W) or high power (500 W) station requirements

A high power Power Supply Module (500 W) is used in a station with a high power Power Amplifier Module (e.g., rated at 100 W or 75 W output power).

A low power Power Supply Module (250 W) is used in a station with a low power Power Amplifier Module (e.g., rated at 40 W output power), or if the station is configured as a Satellite Receiver.

ac Input Power	<p>The 250 W models generates the +5.1 V and +14.2 V operating voltages for the station modules.</p> <p>The 500 W models generates the +5.1 V, +14.2 V, and +28 V operating voltages for the station modules.</p> <p>These modules have power factor correction and include a connection for battery backup.</p>
----------------	--

Table 1. Power Supply Module Models

Model	Supplied by	Input Voltage Range	Output Voltages	Power Factor Correction
Stations with Low Power PA				
DLN6624	ASTECC	85 to 264 Vac, 47 to 63 Hz	+5.1 V and +14.2 V	Provided internally within power supply module.
Stations with High Power PA				
DLN6622	ASTECC	85 to 264 Vac, 47 to 63 Hz	+5.1 V, +14.2 V, and +28 V	Provided internally within power supply module.

Description

dc Input Power For dc-only operation the 250 W Power Supply Module (DLN6624) accepts a dc input (+10.8 to +16 Vdc). The output voltages are:

- the input filtered voltage.
- a regulated +5.1 Vdc.

For dc-only operation the 500 W Power Supply Module (DLN6622) accepts a dc input (+21 to +32 Vdc).

The output voltages are:

- the input filtered voltage.
- a regulated +5.1 Vdc.
- a regulated +14.2 Vdc.

THIS PAGE INTENTIONALLY LEFT BLANK

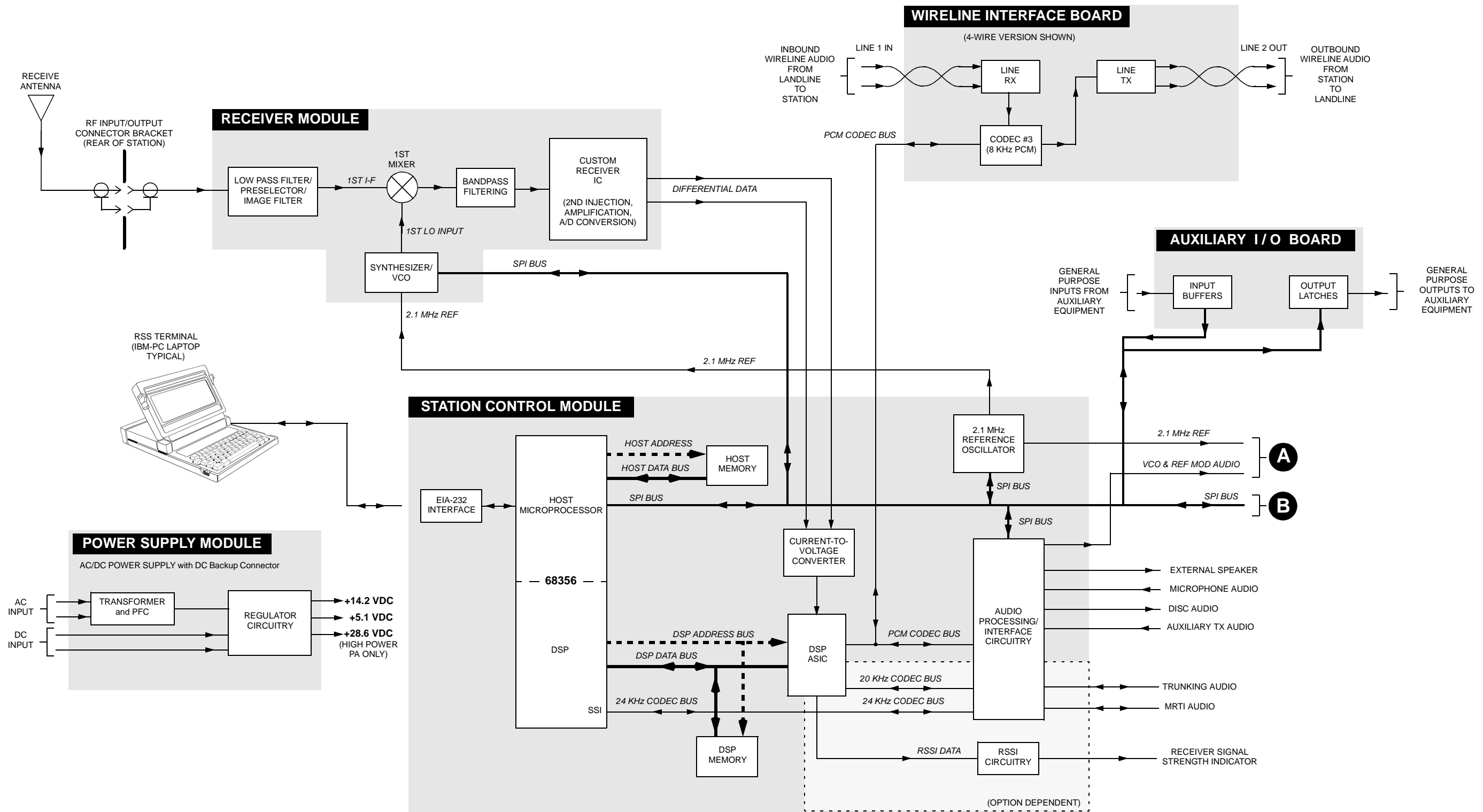

Figure 3. MTR2000 Station Functional Block Diagram (Sheet 1 of 2)

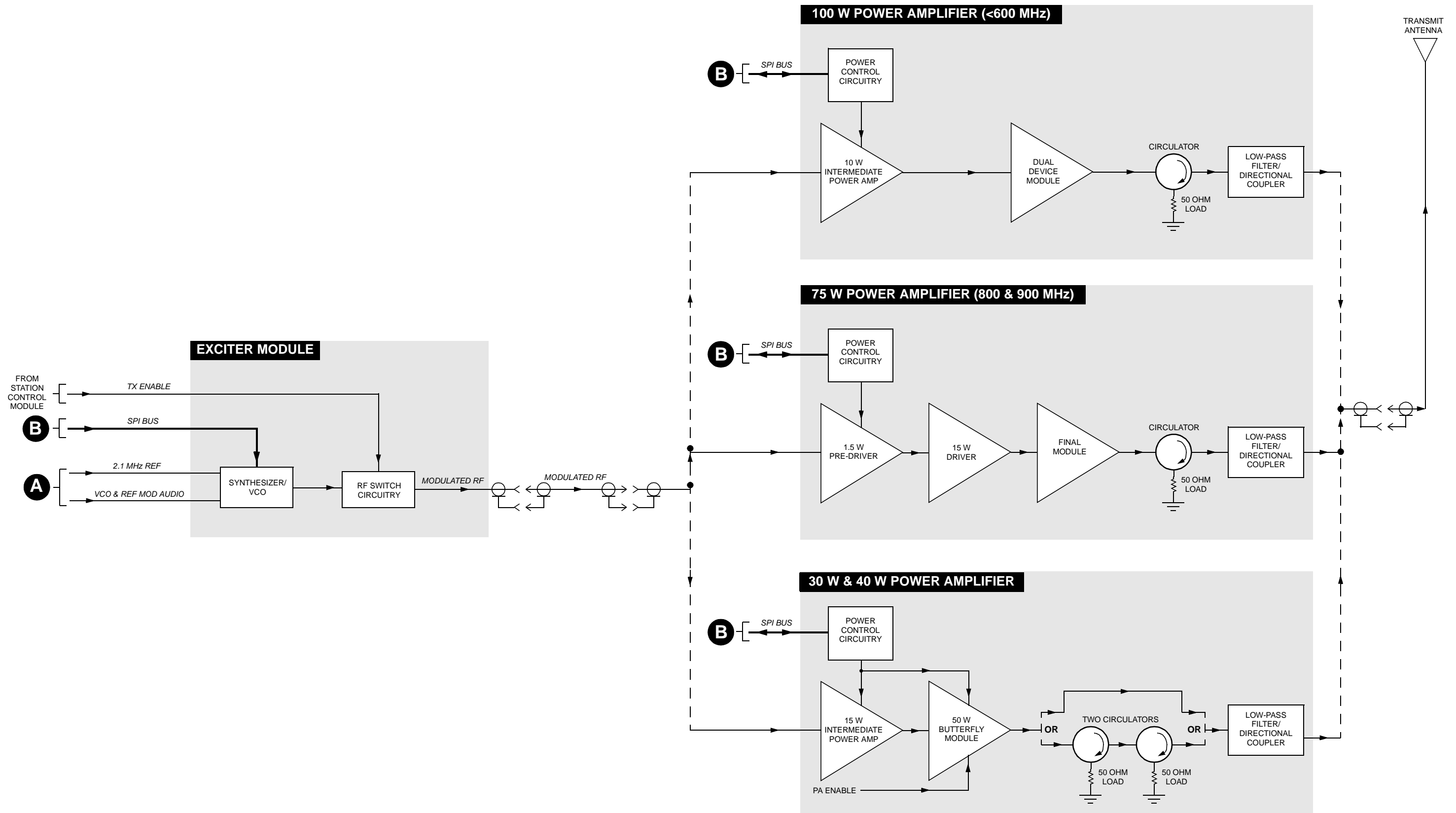

Figure 3. MTR2000 Station Functional Block Diagram (Sheet 2 of 2)

1

PRE-INSTALLATION CONSIDERATIONS

Proper installation ensures the best possible performance and reliability of the station equipment. Pre-installation planning is required. This includes considering the mounting location of the equipment in relation to input power, antennas, and telephone interfaces. Also to be considered are site environment conditions, the particular mounting method (several available), and required tools and equipment.

If this is the first time installing this type of equipment, it is highly recommended that the user read:

- this entire installation section before beginning the actual installation, and
- the Motorola Quality Standards Fixed Network Equipment Installation manual, R56 (68P81089E50); specifically refer to the information on ground connection for lightning protection.

Installation Overview

The following information is an overview for installing the station and ancillary equipment. Step-by-step procedures for each of the major installation tasks are then provided beginning in Section 2, Mechanical Installation.

- Plan the installation, paying particular attention to environmental conditions at the site, ventilation requirements, and grounding and lightning protection.
- Unpack and inspect the equipment
- Mechanically install the equipment at the site
- If a Wireline Interface Board or an Auxiliary I/O Board is included with the station, configure the board jumpers for required operation
- Make necessary electrical and cabling connections, including the following:
 - AC input cabling
 - Coaxial cables to transmit and receive antennas
 - Phone line connections
 - System cables

- Perform a post-installation functional checkout test of the equipment to verify proper installation
- Proceed to the Optimization procedures to customize the station parameters per customer specifications (e.g., operating frequency, PL, codes, etc.)

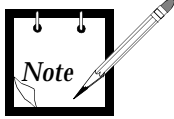

Regulatory requirements may require the use of an optional high stability reference for some modes of operation. It is recommended that the user check current local regulations prior to operation.

Environmental Conditions at Intended Installation Site



IMPORTANT

If the station is to be installed in an environment which is unusually dusty or dirty (and so does not meet the air quality requirements), the air used to cool the station modules must be treated using appropriate filtering devices. Dust or dirt accumulating on the internal circuit boards and modules is not easily removed, and can cause such malfunctions as overheating and intermittent electrical connections.

The station may be installed in any location suitable for electronic communications equipment, provided that the environmental conditions do not exceed the equipment specifications for temperature, humidity, and air quality. These are:

Operating Temperature
Range

-30°C (-22°F) to +60°C (+140°F)

This is the temperature measured in close proximity to the station. For example, if the station is mounted in a cabinet, the temperature within the cabinet would be measured.

Humidity

Not to exceed 95% relative humidity @ 50°C (122°F).

Air Quality

For equipment operating in an environmentally controlled environment with the station(s) rack mounted, the airborne particulates level must not exceed 25 µg/m³.

For equipment operating in an area which is not environmentally controlled (station(s) cabinet mounted), the airborne particulates level must not exceed 90 µg/m³.

Equipment Ventilation

The high-power (100/75W) stations are equipped with cooling fans that are used to provide forced convection cooling.

When planning the installation, observe the following ventilation guidelines:

Mounting the MTR2000 in a Cabinet



- Customer-supplied cabinets must be equipped with ventilation slots or openings in the front (for air entry) and back or side panels (for air to exit). If several stations are installed in a single cabinet, be sure ventilation openings surround each station to allow for adequate cooling.
- All cabinets must have a least 15 cm (6 in) of open space between the air vents and any wall or other cabinets. This allows adequate air flow.
- When multiple cabinets (each equipped with several stations) are installed in an enclosed area, make sure the temperature within each cabinet does not exceed the recommended / maximum operating temperature of +60° C (+140° F). It may be necessary to have air conditioning or other climate control equipment installed to satisfy the environmental requirements.

High Power Stations: The mounting of only ONE STATION PER CABINET is recommended. More than one station per cabinet will result in degradation of thermal specifications at high ambient temperatures.

Low Power Stations: In order to maintain thermal specification of -30° C (-22° F) to +60° C (+140° F), the low power stations must be mounted in a cabinet with additional cooling. A single low power station mounted in a cabinet without additional cooling, will operate at thermal specification performance of -30° C (-22° F) to +54° C (+129° F).

Appropriate precautions should be taken to ensure that station ambient temperature does not exceed +60° C (+140° F).

If multiple stations are required, AND THERMAL SPECIFICATION DEGRADATION IS ACCEPTABLE, the following is recommended when no cabinet fans are used. Up to three stations can be mounted in a 76.2cm (30in) or larger cabinet with two rack units of spacing between each station. This will result in thermal specification performance of -30° C (-22° F) to +40° C (+104° F).

Mounting the MTR2000 in a Rack



When mounting multiple stations in a rack, ensure that the minimum spacing between stations is:

- 3 rack units (13.3cm or 5.25in) for VHF and UHF low power stations, and 350MHz stations.
- 1 rack unit (4.4cm or 1.75in) for VHF and UHF high power stations, 800MHz stations, and 900MHz stations.

This spacing needs to be complied with to ensure that the thermal rating of the station is not exceeded.

AC Input Power Requirements

The station is equipped with a switching power supply, this assembly operates from 85 Vac to 264 Vac at 47 to 63 Hz ac input power. A standard 3-prong line cord is supplied to connect the power supply to the ac source.

It is recommended that a standard 3-wire grounded electrical outlet be used as the ac source.

The ac socket-outlet must be installed near the equipment and must be easily accessible.



The outlet must be connected to an ac source capable of supplying a maximum of 1020 VA. For a nominal 110/120Vac input, the ac source must supply 8.5 A and should be protected by a circuit breaker rated at 15 A. For a nominal 220/240Vac input, the ac source must supply 4.25 A and should be protected by a circuit breaker rated at 10 A.

Requirement for European Union (EU) Countries

Beginning January 1, 2001, input harmonic current specifications were changed for most electronic telecommunication equipment installed in EU countries. Accordingly, power factor correction is necessary for MTR2000 stations.

Power Supply models DLN6622 and DLN6624 have internal power factor correction.

Equipment Mounting Methods

The station equipment may be mounted in a rack or cabinet (available as options).

The station can be shipped:

- ...in an floor-mount indoor cabinet. Each floor-mount cabinet has front and rear vented doors and has the capacity to hold a minimum of a single station (see thermal limitations described under Equipment Ventilation), and required ancillary equipment. The larger cabinets provide additional room for supplementary peripheral equipment.
- ...in a rack. Open frame racks accept multiple stations and ancillary equipment; EIA 48.3cm (19in) rack configuration.

Floor-mount Cabinet

The physical dimensions for all available floor-mount cabinets are shown in Figure 2. All dimensions are common to all cabinets, except for cabinet height. The cabinet options and associated height are:

Cabinet Option	Height
X52AF	76.2 cm (30 in)
X308AD	1.168 m (46 in)
X180AC	1.524 m (60 in)

Minimum recommended clearances are 76.2 cm (30 in) front and 91.44 cm (36 in) rear for minimum installation access. Refer to Equipment Ventilation for recommended ventilation clearances.

For improved access to the unit, a tray slide is available; option X968AA.



Ensure that the cabinet is securely anchored to the floor, thereby avoiding possible equipment tipping and personal injury. Refer to Mounting Procedures – Mounting Floor-mount Cabinets for details on proper cabinet installation.

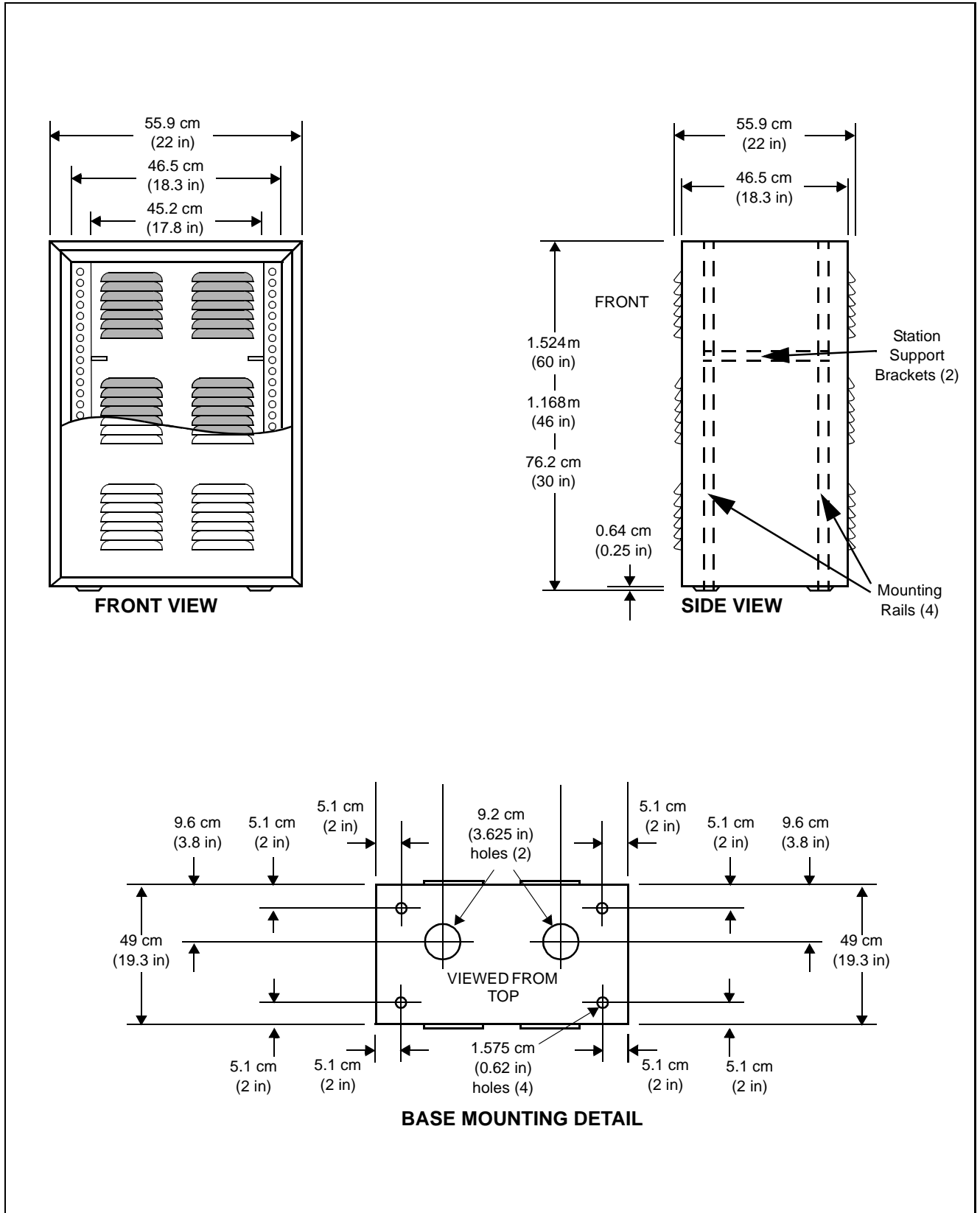

Figure 1. Floor-mount Cabinet - Dimensions and Clearances

Modular Racks

The rack options, associated height and available number of racking units are:

Rack Option	Rack Height	Number of Racking Units
X741AF	76.2 cm (30 in)	16
X742AF	1.143 m (45 in)	24
X743AF	1.32 m (52 in)	27

The physical dimensions and clearances for all available modular racks are shown in Figure 2. The top and bottom plates are identical. All dimensions and clearances are common to all racks, except for the 2 dimensions identified below. The rack options and associated dimensions are:

Rack Option	Dimension A	Dimension B
X741AF	79.2 cm (31.2 in)	26.1 cm (10.27 in)
X742AF	1.147 m (45 in)	27.25 cm (10.73 in)
X743AF	1.28 m (52 in)	31.15 cm (12.26 in)

Recommended clearance front and rear is 91.44 cm (36 in) minimum for servicing access. Refer to Equipment Ventilation for recommended ventilation clearances.

FRU kit CLN6679A (MTR2000 Rack Mounting Hardware) is included with each Rack Option. This allows proper installation of the MTR2000 station within the rack's centre of gravity.



This kit includes two rack mount standoffs and eight mounting screws.

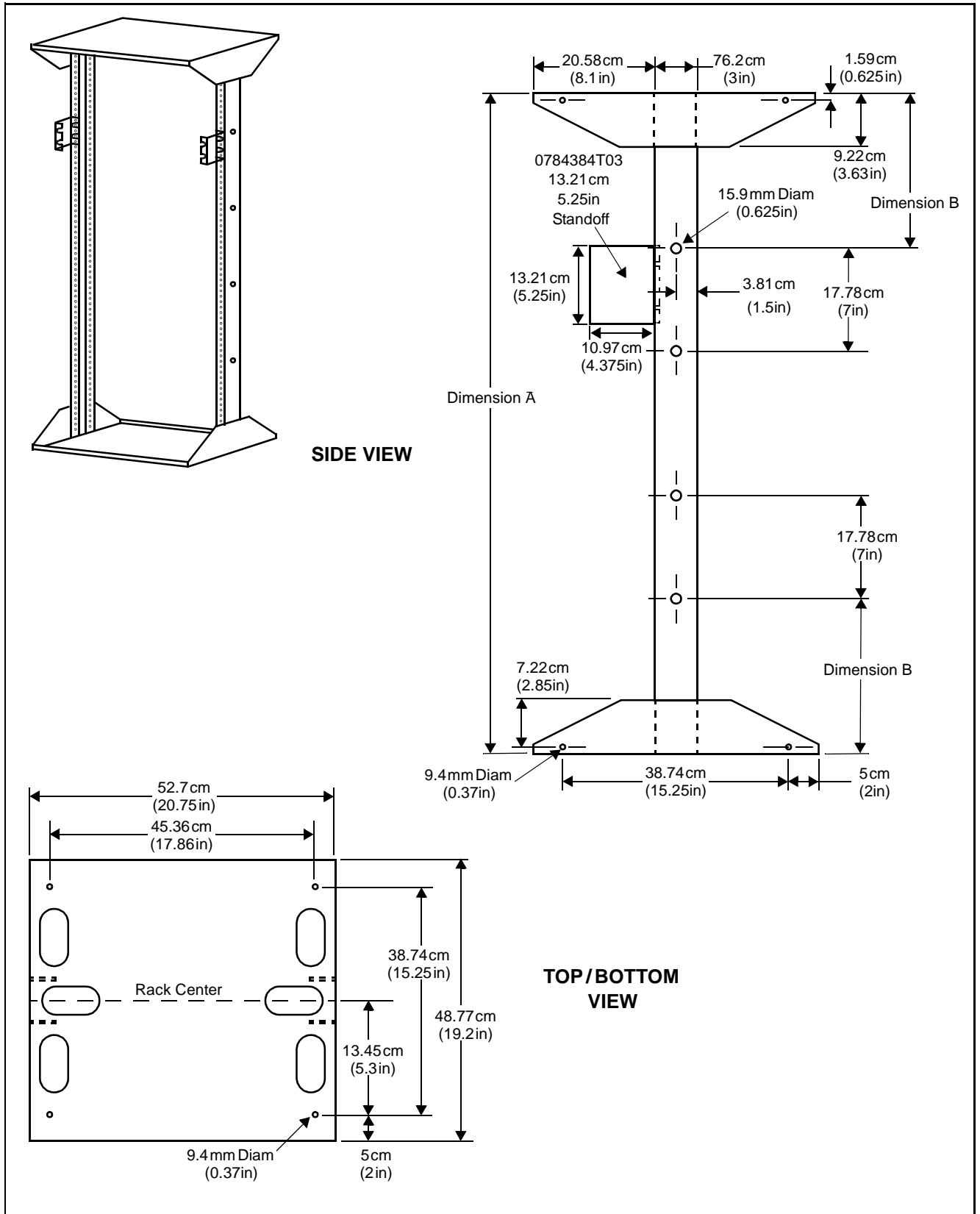

Figure 2. Modular Rack – Dimensions and Clearances

Site Grounding and Lightning Protection



IMPORTANT

Site Grounding Lightning Protection Recommendations

Proper site grounding and lightning protection are vitally important considerations. Failure to provide proper lightning protection may result in permanent damage to the radio equipment.

One of the most important considerations when designing a communications site is the ground and lightning protection system. While proper grounding techniques and lightning protection are closely related, the general category of site grounding may be divided as follows:

Electrical Ground

Ground wires carrying electrical current from circuitry or equipment at the site is included in the category of electrical ground. Examples include the ac or dc electrical power used to source equipment located at the site, telephone lines, and wires or cables connected to alarms or sensors located at the site.

RF Ground

This type of ground is related to the transmission of radio frequency energy to earth ground. An example of rf grounding is the use of shielding to prevent or at least minimize the leakage of unwanted rf transmissions from communications equipment and cables.

Lightning Ground

Providing adequate lightning protection is critical to a safe and reliable communications site. Telephone lines, rf transmission cables, and ac and dc power lines must all be protected to prevent lightning energy from entering the site building.

Although a comprehensive coverage of site grounding techniques and lightning protection is not within the scope of this manual, there are several excellent industry sources for rules and guidelines on ground and lightning protection at communications sites.



Motorola recommends the following reference source:

Motorola Quality Standards Fixed Network Equipment
Installation manual, R5668P81089E50

Equipment Grounding Guidelines

The station is equipped with a ground screw located on the rear of the station Power Supply module. This screw is used to connect the station to the site ground point. It is assumed that all telephone lines, antenna cables, and ac or dc power cabling has been properly grounded and lightning protected by following the rules and guidelines provided in the above reference.

Recommended Tools and Equipment

In addition to the typical compliment of hand tools, the following tools and equipment are recommended for proper installation of the station equipment.

- Tarpaulin or plastic drop cloth or cover surrounding equipment while drilling concrete anchor holes (for installations where cabinet or rack is being anchored to concrete).
- Vacuum cleaner for removing concrete dust caused by drilling.

Equipment Unpacking and Inspection

The station equipment may be shipped by either air freight or electronic van (as specified by customer), except where noted.

- If no cabinet or rack is desired, the station is shipped in a box; the station is positioned between pieces of cushioned corrugated cardboard.
- All available cabinets are shipped with the station(s) installed in the cabinet, with the cabinet bolted to a wooden skid and covered with a cardboard box with corrugated interior corner braces.
- Stations to be used in open frame racks are shipped with the station and ancillary equipment mounted in the rack and covered by an antistatic plastic bag. All rack shipments are electronic van only.

Thoroughly inspect the equipment as soon as possible after delivery. If any part of the equipment has been damaged in transit, immediately report the extent of the damage to the transportation company and to Motorola.



Antistatic plastic bags should be kept for future shipping/transporting of station.

Cabinet Unpacking



When a station (mounted in a cabinet) is delivered from Motorola, it arrives in suitable packing materials. **If the unpacked equipment is damaged, return it to Motorola in its original packaging.**

Equipment should be handled in its original packaging until it is delivered to its final destination. If the equipment is damaged while being moved without the original packaging, the warranty claim is not valid.

2

MECHANICAL INSTALLATION

This section describes the procedures to unpack and mechanically install the station equipment. A variety of mounting methods are possible, depending on whether a cabinet or rack (if any) has been selected to house the station(s). Installation procedures are provided for each of the cabinet and rack types, as well as the slide rail.



IMPORTANT

Be sure to observe proper electrostatic discharge precautions if modules must be removed from the station.

Unpacking Equipment

Introduction

Station equipment packing methods vary depending upon the type of optional rack or cabinet selected by the customer. Unpacking procedures for these various methods are provided in the following paragraphs.



IMPORTANT

The equipment must be immediately inspected for damage after unpacking, and a report of the extent of any damage made to the transportation company and to Motorola.

Unpacking Stations

The station is shipped in a carton, cushioned by four plastic inserts at the corners of the carton.



WARNING

Improper handling of the station may cause personal injury or damage to the station. DO NOT pick up the station by holding the Preselector (if so equipped). Use the handles on the front of the station, or the Power Supply and Power Amplifier casings when picking up the station.

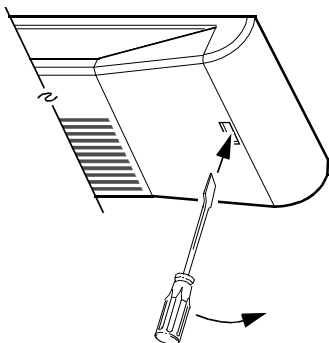

Front Panel – Removal and Replacement

Remove station front panel by inserting a small flat-blade screwdriver into one of two access holes at either end of the panel and, by carefully moving the handle of the screwdriver away from the center, release the front panel locking clip from the chassis and pull away the panel.

Replace station front panel by inserting one of the front panel locking clips into corresponding latch on the station housing, and carefully pressing the panel on the opposite side until the second locking clip snaps into place.

Unpacking Floor-mount Cabinets

The floor-mount cabinets are shipped mounted to a wooden skid, secured with corrugated corner braces held by a plastic strap, and covered with a cardboard cover. Unpack the equipment as described in Figure 3.

1. Remove cardboard cover from station.

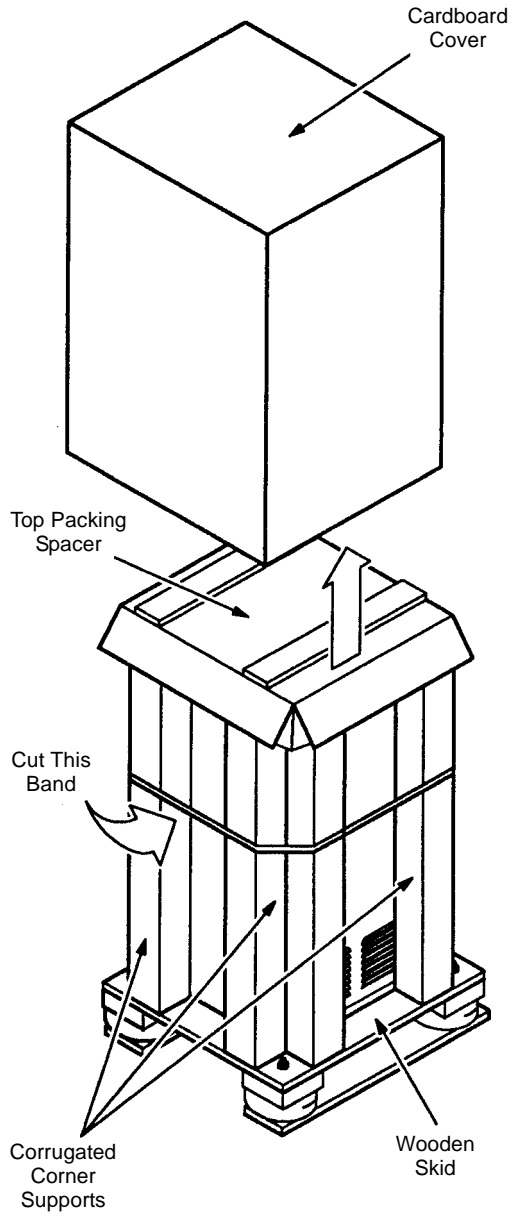

2. Cut band as shown.
3. Remove top packing spacer and corrugated corner supports.

4. Remove antistatic bag. **Do not** discard bag, it will be reinstalled to protect equipment during installation.

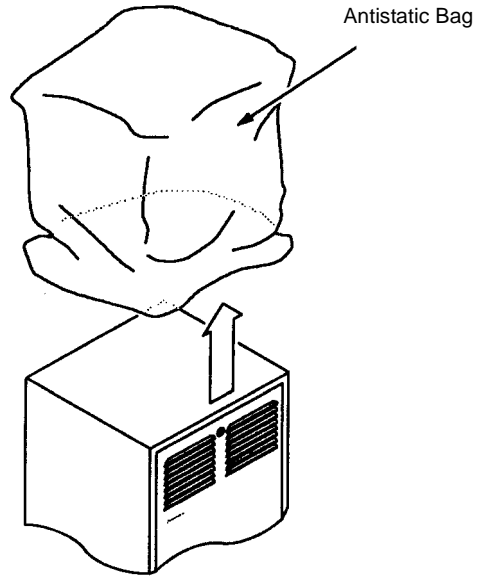

5. Depending on cabinet type, either open or remove front and rear doors to gain access to the four (4) bolts securing the station to the wooden skid. Remove the bolts and nuts as shown.

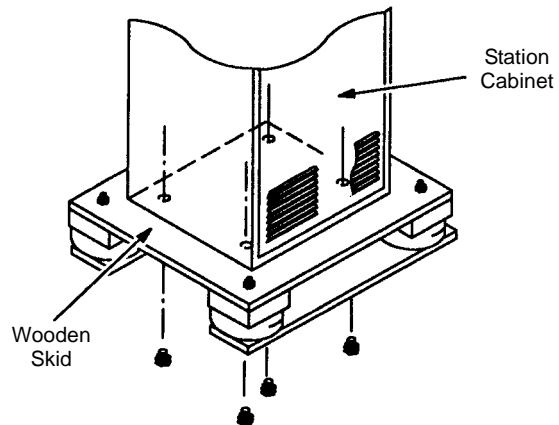

6. Use hoist to lift the station from the skid. Remove skid and return station to floor.
7. Replace antistatic bag over station to provide protection during installation.

Figure 3. Unpacking Procedures - Floor-mount Cabinets

Mounting Procedures

Introduction

In most cases, stations are shipped in the selected cabinet or rack (i.e., the station is mounted and cabled), and may be installed by following the procedures below. However, the following three scenarios require special mounting procedures:

- Customer plans to mount equipment in customer-supplied rack or cabinet, and orders equipment to ship from the factory without a rack or cabinet.
- Customer orders two stations in a single rack.
- Customer requires slide rail assembly.

Installing Racks

In a typical installation, the rack is bolted to a concrete floor to provide stability.

The following procedure describes the steps necessary to bolt the rack to a concrete floor. Be sure to check with local authorities to verify that the following procedure conforms to local building codes and regulations *before permanently installing the rack*.

1. Carefully align the rack at the desired anchoring location.
2. Use the rack mounting foot as a template and mark the location of the six 19 mm (3/4 in) diameter mounting holes. All six anchoring positions must be used.
3. Move the rack aside, drill holes in the concrete floor, and install the mounting anchors (RAM RD-56 anchors recommended) per instructions provided with the anchors. Make sure that none of the anchors comes in contact with the reinforcing wire mesh buried in the concrete; the rack must be electrically isolated from any other equipment or materials at the site.
4. Align the rack with the installed anchors and lightly secure the rack to the floor using the proper mounting hardware. **Do not tighten the mounting hardware at this time.**
5. Check the vertical plumb of the rack. Also check that the top is level. Use shims (flat washers or flat aluminum plates) as necessary under the rack mounting foot to achieve vertical plumb and horizontal level.
6. Tightly secure the rack to the floor anchors making sure that it remains vertically plumb and horizontally level.
7. After all debris is removed and cement dust is cleared away, remove whatever protective covering has been placed on the equipment, including the antistatic bag.



Cement dust from concrete flooring is harmful to electronic equipment and wiring. Make sure that the rack and any collocated equipment are protected prior to drilling holes in the concrete floor. Use a tarpaulin, cloth, or plastic sheeting to cover exposed equipment. (The rack should be already covered with an antistatic bag; do not remove the bag at this time.) Use a vacuum while drilling the holes to minimize the spread of concrete dust. Carefully clean up any accumulated dust and debris from the anchor installation before uncovering the equipment.

Mounting Floor-mount Cabinets

Each cabinet bottom is pre-drilled with four (4) mounting holes to allow attachment to the site floor. If installing on a concrete floor, use the cabinet as a template, mark the hole locations, and follow the procedures above for anchoring equipment racks. If installing on a wooden floor, use lag bolts and washers (customer supplied) to secure the cabinet to the floor.

Transferring Equipment from Shipping Container to Rack or Cabinet

As mentioned under Equipment Unpacking and Inspection, a station can be shipped in a box. Upon delivery, the equipment must be removed from the container and transferred to a Motorola-supplied rack or cabinet, or to a customer-supplied rack or cabinet.



Customer-supplied cabinets and racks must have mounting rails and hole spacing compatible with EIA Universal 48.3cm (19in) specifications. Cabinets must provide adequate ventilation (as detailed under Equipment Ventilation) and must meet the following criteria:

- 41.3cm (16.25in) deep
- 48.3cm (19in) wide
- 13.4cm (5.25in) high
- Two mounting rails 5 cm (2in) from front of cabinet with front mounting holes 5.7 cm (2.25in) apart (center to center).

Contact Motorola Engineering for specific questions regarding mounting equipment in customer-supplied cabinets.

Installing Slide Rail Assembly in a Motorola Cabinet

Referring to Figure 4, perform the following procedure to install slide rail option X968AA.

On a bench-top, working on one side of the slide rail assembly at a time...

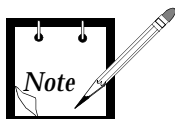

Working in the cabinet...

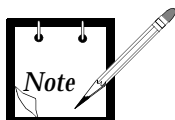

1. Remove the Inner-Slide Rail from the slide assembly (left and right) by depressing the Slide Locking Latch and sliding the Inner-Slide Rail out from the slide assembly.
2. Install the Inner-Slide Rail (left) on the Power Supply side by:
 - removing the 2 bottom screws from the station power supply EMI cover, and
 - installing the Inner-Slide Rail (left) with the supplied screws.
3. Install the Inner-Slide Rail (right) on the PA side using the holes in the PA casing.
4. Attach each Outer-Slide Rail to a Cabinet Bracket with supplied screws.

The left and right Cabinet Brackets are identical.

The Locking Tab of each Outer-Slide Rail must face towards the rear of the cabinet.

5. The cabinet must have a set of vertical cabinet rails in the back as well as the front. If there is no set in the back, these must be installed. The back rail is installed the same as the front rail, with the supplied screws.
6. Install each assembled Cabinet Bracket (with attached Outer-Slide Rail) to the appropriate side of the cabinet.

The U-shaped cutout of the Cabinet Bracket must face up.

7. Slide the station (with an Inner-Slide Rails mounted on each side) into the Outer-Slide Rails in the cabinet; an audible snap is heard. Continue sliding the station in until the station is fully seated.
8. Secure the station to the cabinet front rails with the supplied screws.

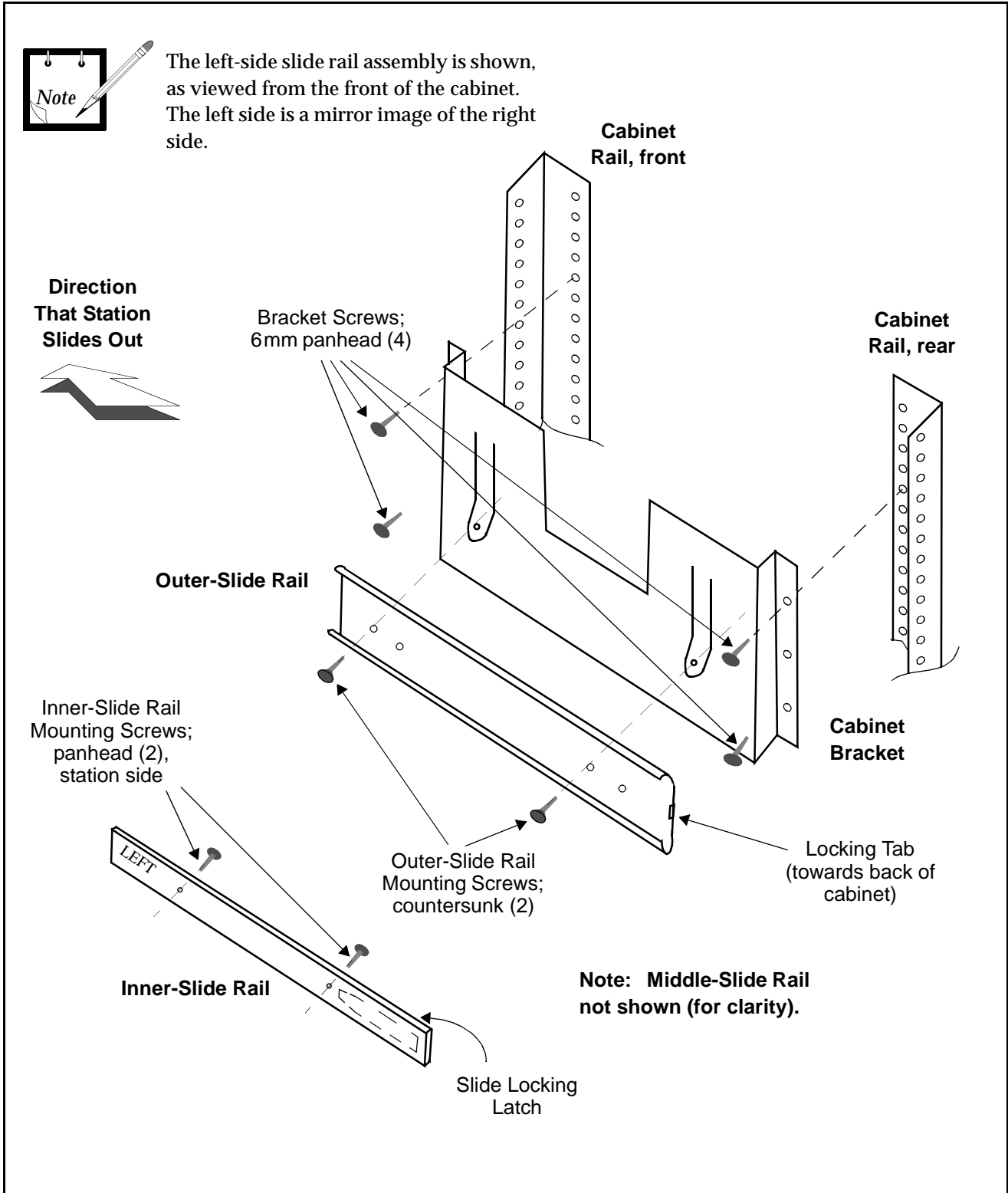

Figure 4. Slide Rail Installation; Option X968AA (Left Side Shown)

Installing Slide Rail Assembly in a Non-Motorola Cabinet

Referring to Figure 5, perform the following procedure to install slide rail option X346AB.

On a bench-top, working on one side of the slide rail assembly at a time...

1. Remove the Inner-Slide Rail from the slide assembly (left and right) by depressing the Slide Locking Latch and sliding the Inner-Slide Rail out from the slide assembly.
2. Install the Inner-Slide Rail (left) on the Power Supply side by:
 - removing the 2 bottom screws from the station power supply EMI cover, and
 - installing the Inner-Slide Rail (left) with the supplied screws.
3. Install the Inner-Slide Rail (right) on the PA side using the holes in the PA casing.
4. Attach each Outer-Slide Rail to the cabinet Brackets with supplied screws. Only use the lower slot of each bracket. Leave the screws loose; they will be tightened when the brackets are mounted in the cabinet (step 7).



Working in the cabinet...

The left and right Cabinet Bracket sets are identical. The Locking Tab of each Outer-Slide Rail must face towards the rear of the cabinet.

5. Install a cage nut in line with clearance hole in Threaded Strip prior to fitting the Front Bracket to the front cabinet rail. This nut is required for mounting the station (in step 9). The cage nuts are provided with the cabinet.
6. Fit the Short Bracket and Long Bracket (with attached Outer-Slide Rail) to the Front and Rear Cabinet Rails using the Bracket Mounting Screws and Threaded Strips.
7. Tighten the Outer-Slide Rail hardware after positioning the Outer-Slide Rail front side in line with the inner surface of the Front Cabinet Rails.
8. Slide the station (with an Inner-Slide Rails mounted on each side) into the Outer-Slide Rails in the cabinet; an audible snap is heard. Continue sliding the station in until the station is fully seated.
9. Secure the station to the Front Cabinet Rails with the supplied Station Mounting Screws.

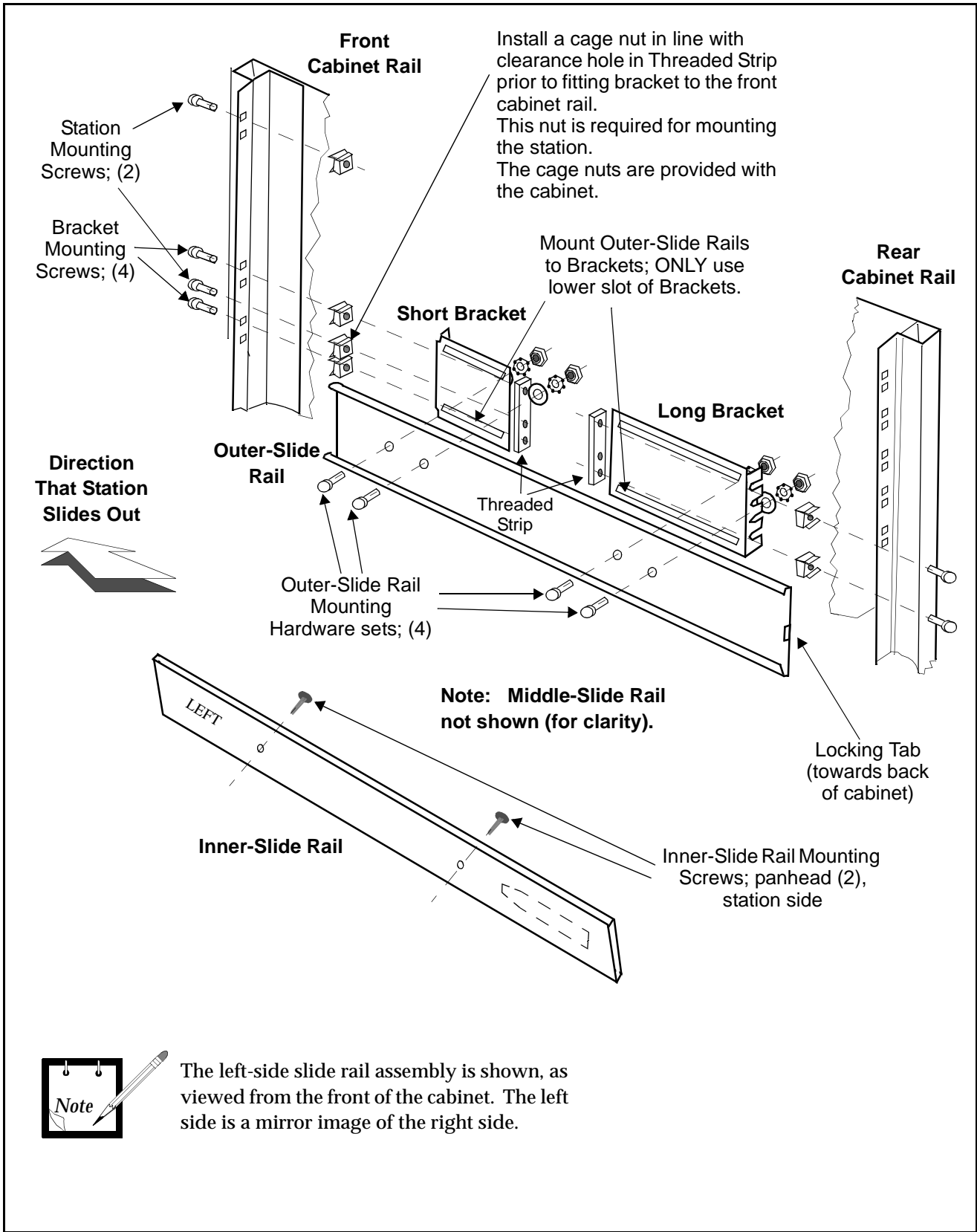

Figure 5. Slide Rail Installation; Option X346AB (Left Side Shown)

3 BOARD CONFIGURATION

Most station configuration parameters are altered through the Radio Service Software (RSS) with the exception of some parameters for the following boards, which are configured through jumpers:

- 4-Wire Wireline Interface Board (CLN1203),
- 4-Wire Euro Wireline Interface Board (CLN1204),
- Auxiliary I/O Board (CLN1206).

4-Wire Wireline Interface Board

Model CLN1203 WIB supports tone control of the station. CLN1203 provides a fixed impedance of 600Ω to the wireline. Figure 6 shows the jumper locations for tone control.

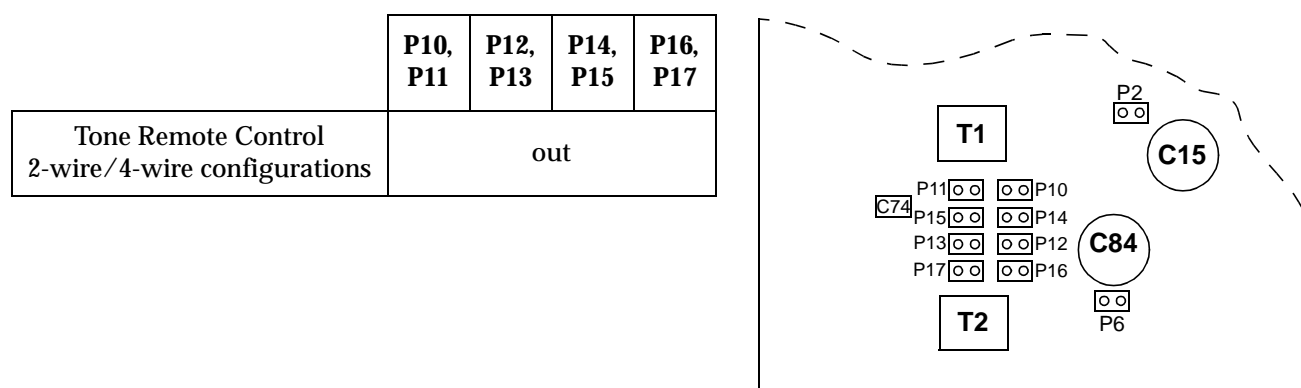

Figure 6. CLN1203 Wireline Interface Board Jumper Settings

4-Wire Euro Wireline Interface Board

Figure 7 shows the correct settings of impedance matching jumpers for the model CLN1204 WIB, as determined by the country in which the station is being operated. Incorrect jumper settings may violate local telecommunications authority regulations and place the equipment in an unapproved status. Some countries also specify a maximum allowed line input level. Refer to the RSS Online Help, under Line Level.

Country	Reference Impedance	P1, P5, P8, P9					P3, P7
		A *	B	C	D	E	
Australia				✓			✓
Spain				✓			✓
Austria				✓			✓
Germany (2-wire)				✓			✓
Luxemburg				✓			✓
South Africa				✓			✓
Switzerland				✓			✓
Belgium				✓			✓
Cyprus		✓					✓
Former USSR		✓					✓
Former Yugoslavia		✓					✓
Germany (4-wire)		✓					✓
Greece		✓					✓
Italy		✓					✓
Netherlands		✓					✓
Portugal		✓					✓
Denmark						✓	
Ireland					✓		✓
UK					✓		✓
Finland			✓				✓
France			✓				✓
Norway			✓				✓
Sweden						✓	

√ = Jumper In
A = Pin 1 connects to Pin 2
 * This setting represents a standard 600 ohm matching and is the factory default.
B = Pin 3 connects to Pin 4
C = Pin 5 connects to Pin 6
D = Pin 7 connects to Pin 8
E = Pin 9 connects to Pin 10

Note Canada and the U.S wireline requirements are supported by Wireline board model CLN1203.

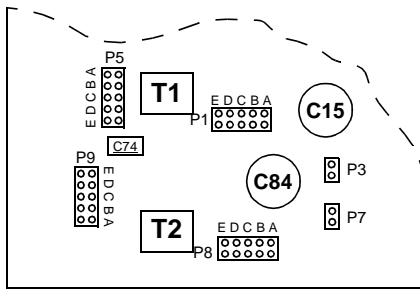

Figure 7. CLN1204 Wireline Interface Board Jumper Settings

Auxiliary I/O Board

Jumpers are provided to route inputs and outputs in a specific direction to and from the SCM; the SCM determines the functionality of the inputs and outputs.

The board jumpers are shown in Figure 8.

GPI_14 is a special input which can be jumpered to be a transistor input or opto isolated. In addition it can be dedicated to the Ext_PTT* Line routed to the SCM. This function is a fast external PTT* (an active low function).

The board jumper settings for P2, P9, P6 are provided in Table 1. Settings for P5 are provided in Table 2. Settings for P3, P4 are provided in Table 3.

P7 and P8 are not used.

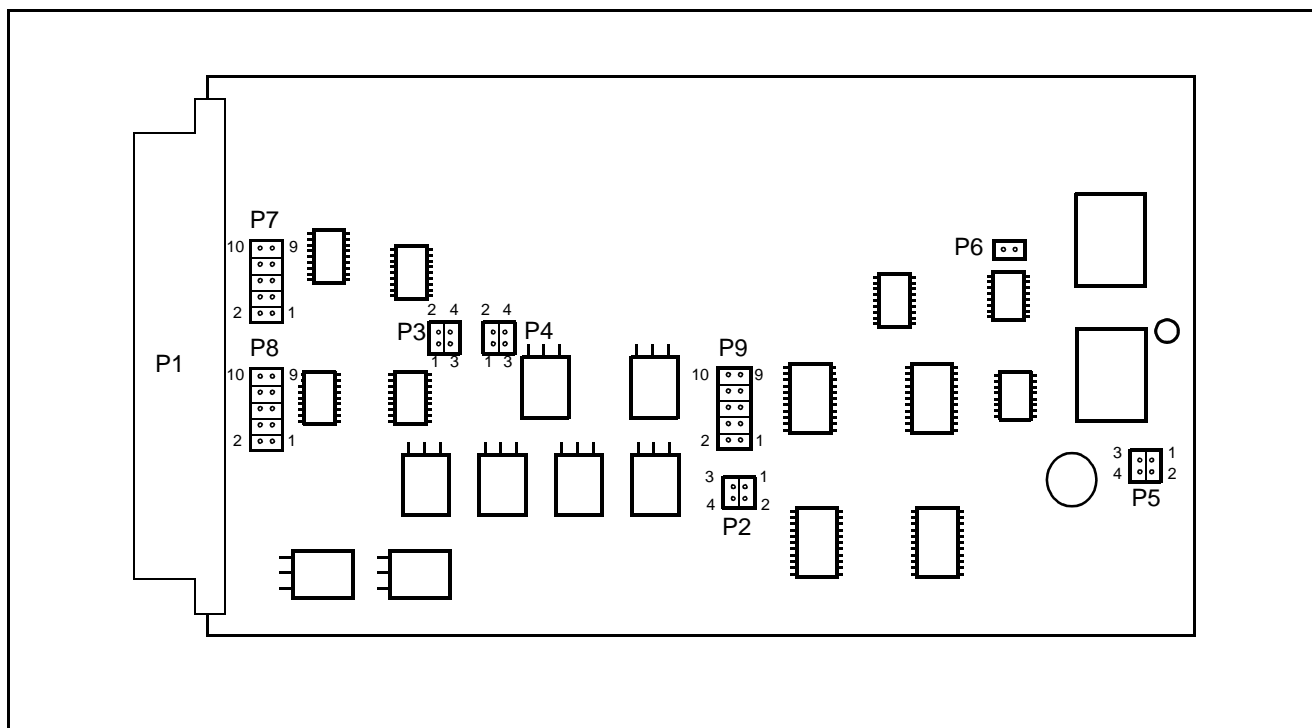

Figure 8. CLN1206 Auxiliary I/O Board Jumpers

Table 1. Configuring Input GPI_14 Function

Function on GPI_14	Input Type	System Connector Input Pins	Auxiliary I/O Board Jumpers		
			P2	P9	P6 (See Note 1)
$\overline{\text{Fast External PTT}}^*$	via Optocoupler (E/M sub). (See Note 2)	A29 Opto + A26 Opto -	3 - 4, 1 - 2		In
	via Transistor	B26		9 - 10, 7 - 8	In
Fast External PTT	via Optocoupler (E/M sub)	A29 Opto + A26 Opto -	3 - 4, 1 - 2		Out
	via Transistor	B26		9 - 10, 7 - 8	Out

Table 2. Configuring Output GPO_14 Function

Function on GPO_14	Output Type	System Connector (J5) Output Pins	Auxiliary I/O Board Jumper P5
AC Fail	via Relay Closure	B29, A30	2 - 4
SPI Latch for GPO_14 (software defined)	via Relay Closure	B29, A30	1 - 2



The shaded areas indicate default manufacturing settings.

Note 1: This is an active low; that is, no current to the Opto Input.

Note 2: This configuration, with P6 out (PTT when current to the Opto Input) represents the E Signal of 4 wire E&M Trunk Type I Phone Signalling. The opposite direction of the E&M is covered in Note 3.



In this configuration the second remaining unused input type must be jumpered to the SPI Buffer. The Buffer Input should never be left floating; otherwise the IRQ Generator will not function properly (i.e., use either P2-1&2 or P9-7&8).

Table 3. Configuring Output GPO_15 Function

Function on GPO_15	Output Type	System Connector (J5) Output Pins	Auxiliary I/O Board Jumpers	
			P3	P4
Fast Carrier Detect	via Relay Closure	C3, B3	2 - 4	2 - 4
	via Open Collector	B21 (see Note 4)	3 - 4	2 - 4
RdStat	via Relay Closure (see Note 3)	C3, B3	2 - 4	1 - 3
	via Open Collector	B21 (see Note 4)	3, 4	1, 3
SPI Latch for GPO_15 (software defined)	via Relay Closure	C3, B3	1 - 2	
	via Open Collector	B21 (see Note 4)	1 - 3	



Note 3: This configuration represents the M Signal of 4 wire E&M Trunk Type I Phone Signalling. The opposite direction of the E&M is covered in Note 2.

Note 4: Indicates that the configuration is only available when the board is plugged into Option slot 1.

4

ELECTRICAL CONNECTIONS

After the station equipment has been mechanically installed, electrical connections must be made. This involves making the following connections to:

- power supply,
- antenna coax cables,
- system cables, and
- telephone lines.



When installing option boards, ensure that an Electro-Static Discharge (ESD) cable is connected (via banana plug) to the hole in the front-right handle of the station when installing option boards. Otherwise, the option boards may be damaged.

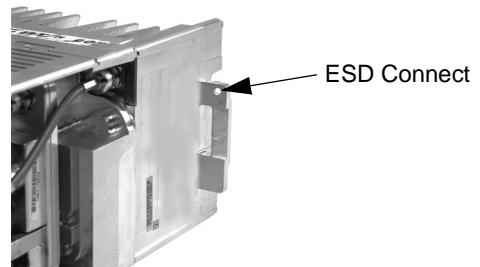

There are also electrical connections associated with maintenance and troubleshooting of the station. These connectors are located on the front of the Station Control Module (see Station Operation section for position of these connectors).

Figure 9 shows the position of the station external connectors located at the rear of the station.

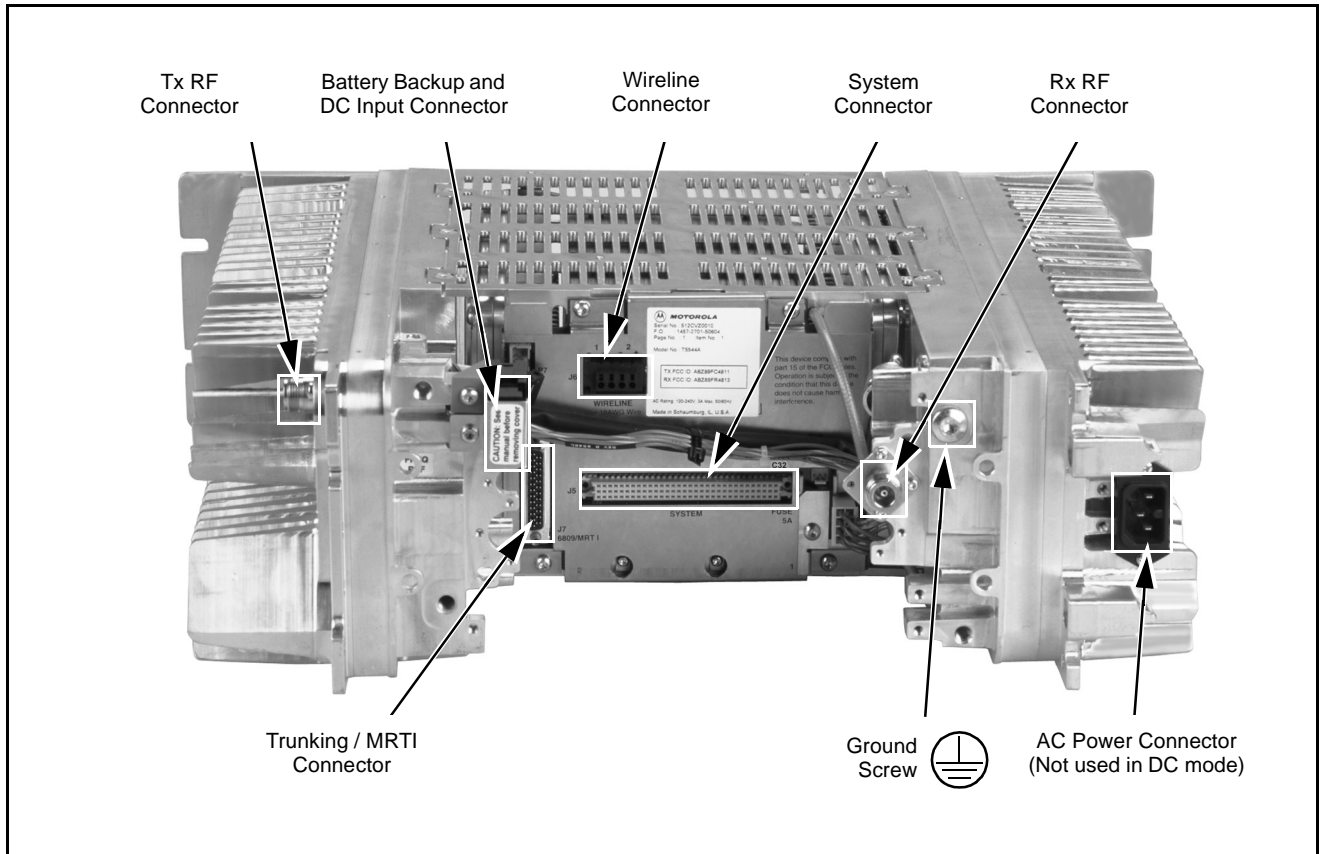

Figure 9. Location of External Connectors at Rear of Station

Power Supply Connections



AC Input Power Connection

Do not apply ac power to the station at this time. Make sure that the circuit breaker associated with the ac outlet is turned to OFF.

The ac socket-outlet must be installed near the equipment and must be easily accessible.

Each station is shipped with an 2.5 m (8ft) 3-conductor line cord. Figure 9 shows the ac line cord connector. Insert the plug into an appropriate grounded outlet.

The North American line cord is equipped with a NEMA 5-15 plug, intended for 110/120Vac operation.

The optional European line cord (Option X189AA) is equipped with a “Schuko” style CEE VII (7) plug, intended for 220/240VAC operation.

Plugs for other countries are available as the following options:

Location	Option Number
U. K.	X162AD
Australia	X191AD

If an alternate line cord is required, obtain a line cord employing “HAR” flexible cord with fittings approved by the safety testing agency in the end-use country.

Ground Connection

The station is equipped with a ground screw located on the rear of the station Power Supply module. Connect the ground screw to the site ground point.



CAUTION

Refer to Motorola Quality Standards Fixed Network Equipment Installation manual, R56 (68P81089E50) for complete information regarding lightning protection.



CAUTION

The station is to be connected to a battery supply that is in accordance with the applicable electrical codes for the end use country; for example, the National Electrical Code ANSI/NFPA No. 70 in the U.S.

DC Input Power Connection

For DC-only operation, the DC source power is connected to the station through the battery backup connector shown in Figure 9, and described in “Battery Connection” on page 29.



WARNING

Ensure that the appropriate voltage is connected; that is, Nominal 14.2 Vdc (10.8 to 16.0 Vdc) for a low power station, or Nominal 28.6 Vdc(21.0 to 32.0 Vdc) for the high power station.

Battery Connection

Battery backup interface offers the capability of connecting to battery backup power in the event of an AC power line failure.

The battery backup system is connected to the station through the red and black connector mounted at the rear of the station. The connector has a cover with the following label. This label directs the technician to read the information provided below:

CAUTION: See manual before removing cover.

This battery backup system must have, at a minimum, a disconnect relay controlled by an AC fail detector.



WARNING

DO NOT connect a battery directly to the station. Damage to batteries as well as to the station may occur. Batteries must be connected to the station through an Argus Technologies Battery Reverting Charger, Model #010-519-20 (Motorola Model #L1883) for 12V charging systems, and Argus Technologies Model #010-523-20 (Motorola Model #L1884) for 24V charging systems. These systems were developed specifically for this interface and tested by Motorola for proper station operation. Dam-

age resulting from use of any other charging systems will void the warranty. Refer to qualified sales/service representative for charger ordering information.



The station is to be connected to a battery supply that is in accordance with the applicable electrical codes for the end use country; for example, the National Electric Code ANSI/NFPA No.70 for the U.S.

Cables are supplied with the charging option. **Do not make connections directly from the station to the storage battery.** Connect as shown in Figure 10.

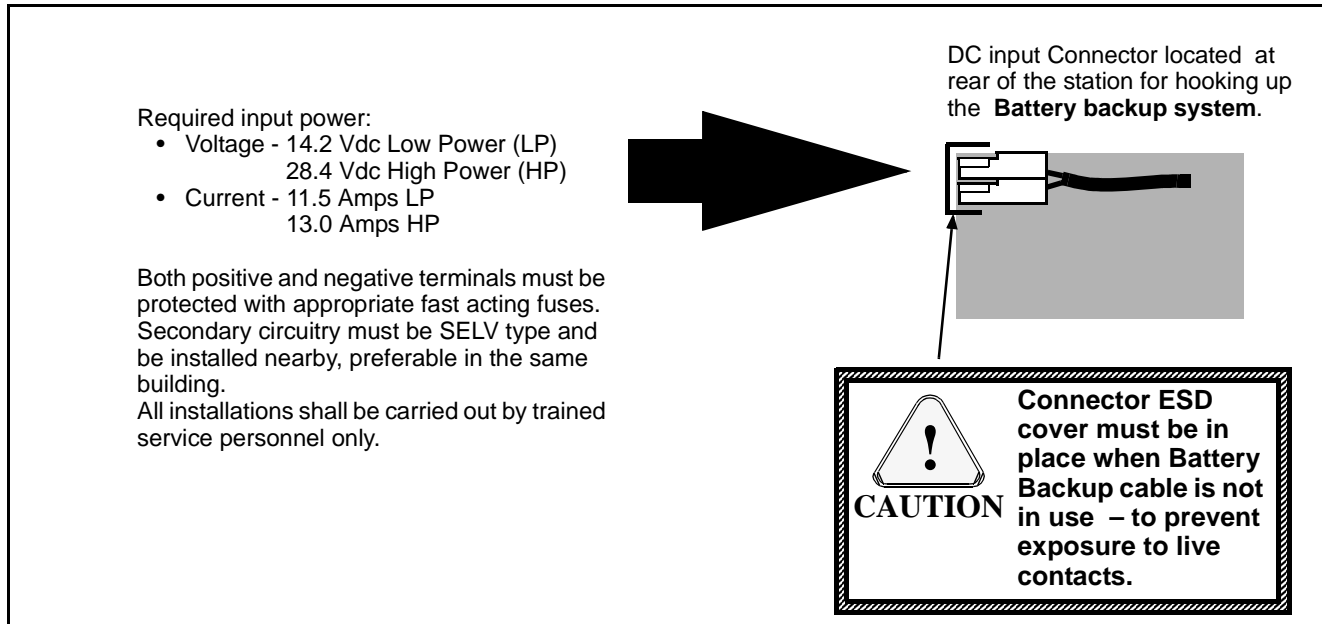

Figure 10. Making Connections to Storage Battery

RF Antenna Connections

The transmit and receive antenna rf connections are made using two separate N-type connectors. Coax cables from the receive and transmit antennas must be connected to the two N-type connectors. The position of these connectors is shown in Figure 9.

In the case where an optional Antenna Relay is used on the station, the coax cable from the single transmit/receive antenna is connected to the middle N-type connector of the Antenna Relay.

System Cable Connections

System connections are made through one or both of the following connectors:

- the Trunking/MRTI connector and
- the System connector.

Trunking/MRTI Connector

The location of the Trunking/MRTI connector and System connector on the station rear panel is shown in Figure 9.

The following cables are available for trunking system applications:

- 7.62m (25ft) Trunk Cable, part # 3083765X04
- 15.24m (50ft) Trunk Cable, part # 3083765X05
- 22.86m (75ft) Trunk Cable, part # 3083765X06
- 30.48m (100ft) Trunk Cable, part # 3083765X07

The following cable is available for MRTI applications:

- Interface cable for Zetron model 30, kit # TTO4097

System Connector

The cable connected to the System connector can be configured for various system options.

A generic System cable is available for variety of applications such as Wild Card, Main Standby, and Auxiliary Input/Output:

- generic System cable, kit # TKN9205A

This cable provides a housing shell for connection to the 96 pin backplane connector, 30 loose pins, and a quantity of 30 of 24 gauge wires (2 meter long with a pin for header on one end and unterminated at the other end).

Table 4 provides a description of commonly used System Connector pins.

Table 4. System Connector – Commonly Used Pins

Pin Function		Pin #	Pin Signal Characteristics
Name	Description		
RdStat	TTL compatible logic output indicating Rx. Activation status.	C2, B21, B3/C3	0.0 to 0.2Vdc with squelched receiver, 4.8 to 5.2Vdc with unsquelched receiver.
Disc. Rx. Audio	Unfiltered and unsquelched discriminator audio without de-emphasis.	C17	80mV minimum to 400mV maximum for 60% system deviation. Output level is RSS programmable.
RSSI	DC output volts related to received carrier level.	C11	Typically 0.5Vdc for -120dBm to 3.5 Vdc for -40 dBm carrier. Variation with carrier level @ approximately 40mV/dBm.
Cntrl 14.2V	14.2 volts dc output. For dc-only 250W power supplies, this voltage is equal to the input supply voltage.	A18, B18, C18 C32, B32, C32	Total current through all of these pins should not exceed 1Amp.
5 V	5.1 ± 0.25 volts dc output.	A20, B20, C20	Total current through all of these pins should not exceed 500 mA.
GND	Ground.	A19, B19, C19 A27, B27, C27 A31, B31, C31	Total current through all of these pins should not exceed 1.5 Amp.
Aux.Tx Audio	Tx. modulation input from external source.	A17	RSS programmable sensitivity. For R03.01 (host software) and earlier, the fixed sensitivity is @ 172 mVrms for 60% system deviation. RSS programmable for pre-emphasized or flat response. DC offset +2.4V. High impedance input.
Ext. PTT	External Tx. keying signal.	C10	Grounding Ext. PTT pin causes Tx to key. 5.0Vdc on pin when Tx is not keyed. Note: To transmit signalling code (PL / DPL) by external PTT, it should be mapped (via RSS) to Wireline, and external modulation input should be routed to wireline.
AC_Fail	Logic output to indicate failure of AC line input.	A4	Requires a Battery Revert dc supply. Line goes high (5.0Vdc) if AC fails.
Wireline Pair 3+/-	Additional wireline for other functions.	C28, C30	Line sensitivity and operation identical to line pairs 1 and 2 (see Table 10).
Wireline Pair 4+/-		B28, B30	

Table 5 provides a summary of the Auxiliary Inputs / Outputs (Wildcard I/O) currently available through the System Connector.

Table 5. Summary of Auxiliary Inputs/Outputs at the System Connector

Auxiliary I/O GPI...	System Connector (J5) Pin	Auxiliary I/O GPO...	System Connector (J5) Pin
3	A5	0	A12
4	C5	2	A11
7	A22	8	A1
9	A28	RX Lock	B1
10	C12	TX Lock	C1
11	B12	13	B2
12	B11	15	B21
13	B9	15 (relay)	C3, B3 See Table 3, on page 25, and B3, C3 in Table 7, on page 36 and Table 8, on page 37.

Details of the System connector pinouts are provided in:

- Table 7, Row A pin assignments
- Table 7, Row B pin assignments
- Table 8, Row C pin assignments

The following symbols and abbreviations are used in Tables 7 to 8:

- * = line is Active Low
- NS = Not Supported; **this pin should not be used.**
- Aux I/O = Indicates that the Aux I/O board must be present for this functionality.
- WCI = Wild Card Input
- WCO = Wild Card Output



The RSS Online Help provides the most current information on the System Connector pin assignments.

Table 6. J5 SYSTEM CONNECTOR, Row A Pins

Pin #	Pin Assignment	Input/ Output	To/From	Signal Characteristics
1	GPO_8 (WCO)	O	J1-C32, J2-C32	OCO, 100mA, 40V
2	PA Fail (Aux I/O)	O	J1-C31, J2-C31	OCO, 100mA, 40V, active low
3	SCI_CLK1	O	J1-C30, J2-C30, J3-C28	Do not use.
4	AC Fail	O	P8-5, J1-C29, J2-C29, J3-C24	TTL output, active high
5	GPI_3 (WCI)	I	J1-C28, J2-C28	Pulled up transistor input, 16V max
6	GPI_15 (-) (NS)	I	J1-C27, J2-C27	Negative side opto-isolated input, see C7
7	Ext Failsoft (Aux I/O)	I	J1-C26, J2-C26	Pulled up transistor input, 16V max
8	GPI_1 (NS)	I	J1-C25, J2-C25	
9	GPI_2 (NS)	I	J1-C24, J2-C24	Pulled up transistor input, 16V max
10	VSWR_Fail* (Aux I/O)	O	J1-C23, J2-C23	Pulled up transistor output (10kohms to +5Vdc), active low
11	GPO_2 (WCO)	O	J1-C22, J2-C22	Pulled up transistor output (10kohms to +5Vdc)
12	GPO_0 (WCO)	O	J1-B25, J2-B25	
13	Antenna Relay	O	P10-1, J3-C26	OCO, 200mA, active low
14	Not Supported	O	J1-C18, J2-C18, J3-C19	
15	Spare 310	-	-	
16	Spare 308	-	-	
17	Aux TX Audio	I	J1-C16, J2-C16, J3-C16	RSS programmable input sensitivity
18	Cntrl 14.2 VDC	O	P8 pins 3, 4 (thru F2)	+14.2Vdc, Note 1
19	GND	-	Station ground	
20	5 VDC	O	P8 pins 7, 8	+5.1 ± 0.25 Vdc
21	Not Supported	O	J3-C12	
22	GPI_7 (WCI)	I	J1-C11, J2-C11	Pulled up transistor input, 16V max.
23	Spare 323	-	-	
24	Spare 320	-	-	
25	Spare 903	-	-	
26	Ext PTT or GPI_14 (-), Note 2	I	J1-C7, J2-C7	Negative side opto-isolated input, see A29
27	GND	-	Station ground	
28	GPI_9 (WCI) or GPO_3 (NS)	I/O	J1-C6, J2-C6	Caution: See Auxiliary I/O section for jumpering information
29	Ext PTT or GPI_14 (+), Note 2	I	J1-C5, J2-C5	Positive side opto-isolated input, see A26
30	AC Fail or GPO_14, Note 3	O	J1-C4, J2-C4	One side of normally open relay, see B29
31	GND	-	Station ground	
32	Cntrl 14.2 VDC	O	P8 pins 3, 4 (thru F2)	+14.2Vdc, Note 1
<p>Note 1: For dc-only 250W power supplies, this voltage is equal to the input supply voltage.</p> <p>Note 2: This pin can be jumpered for Ext PTT (supported) or GPI_14 (not supported). See Aux I/O jumpers P2 and P9.</p>			<p>Note 3: This pin can be jumpered for AC Fail (supported) or GPO_14 (not supported). See Aux I/O jumper P5.</p>	

Table 7. J5 SYSTEM CONNECTOR, Row B Pins

Pin #	Pin Assignment	Input/Output	To/From	Signal Characteristics
1	RX Lock (Aux I/O)	O	J1-B32, J2-B32	OCO, 100mA, 40V; active high
2	GPO_13 (WCO)	O	J1-B31, J2-B31	OCO, 100mA, 40V
3	RdStat or GPO_15, Note 4	O	J1-B30, J2-B30	One side of normally open relay, see C3
4	Carrier Detect Switch	O	J1-B29, J2-B29, J3-B24	TTL output, active high
5	GPI_8 (NS)	I	J1-B28, J2-B28	Pulled up transistor input, 16V max
6	GPI_5 (NS)	I	J1-B27, J2-B27	
7	Ext Repeat* (Aux I/O)	I	J1-B26, J2-B26	
8	Trunk Duplex Enable*	I	J3-B25	TTL input
9	GPI_13 (WCI) or GPO_7 (NS)	I/O	J1-B24, J2-B24	Caution: See Auxiliary I/O section for jumpering information
10	Spare 311	-	N/C	
11	GPI_12 (WCI) or GPO_6 (NS)	I/O	J1-B22, J2-B22	Caution: See Auxiliary I/O section for jumpering information
12	GPI_11 (WCI) or GPO_5 (NS)	I/O	J1-B23, J2-B23	
13	Spare 301	-	N/C	
14	Not Supported	I	J1-B19, J2-B19, J3-B19	TTL input
15	GND	-	Station ground	
16	Spare 300	-	-	
17	Spare 321	-	-	
18	Cntrl 14.2 VDC	O	P8 pins 3, 4 (thru F2)	+14.2Vdc, Note 1
19	GND	-	Station ground	
20	5 VDC	O	P8 pins 7, 8	+5.1 ± 0.25 Vdc
21	RdStat or GPO_15, Note 4	O	J1-B12	OCO, 100mA, 40V
22	Spare 322	-	-	
23	Spare 325	-	-	
24	Spare 309	-	-	
25	Spare 902	-	-	
26	Ext PTT or GPI_14, Note 2	I	J1-B7, J2-B7	Pulled up transistor input, 16V max, see A29
27	GND	-	Station ground	
28	Line 4+	O	J4-C10	Wireline output balanced, (+)
29	AC Fail or GPO_14, Note 3	O	J1-B4, J2-B4	Other side of normally open relay, see A30
30	Line 4-	O	J4-A9	Wireline output balanced, (-)
31	GND	-	Station ground	
32	Cntrl 14.2 VDC	O	P8 pins 3, 4 (thru F2)	+14.2Vdc, Note 1

Note 4: This pin can be jumpered for RdStat (supported) or GPO_15 (supported). See Aux I/O jumpers P3 and P4.

Table 8. J5 SYSTEM CONNECTOR, Row C Pins

Pin #	Pin Assignment	Input/ Output	To/From	Signal Characteristics
1	TX Lock (Aux I/O)	O	J1-A32, J2-A32	OCO, 100mA, 40V; active high
2	Rdstat-R2 Control	O	J1-A31, J2-A31, J3-A26	TTL output, high when unsquelched
3	RdStat or GPO_15, Note 4	O	J1-A30, J2-A30	Other side of normally open relay, see B3
4	Failsoft Output (Aux I/O)	O	J1-A29, J2-A29	OCO, 100mA, 40V, active low
5	GPI_4 (WCI)	I	J1-A28, J2-A28	Pulled up transistor input, 16V max
6	Rx Inhibit	I	J1-A27, J2-A27, J3-B26	TTL input; active low
7	GPI_15 (+) (NS)	I	J1-A26, J2-A26	Positive side opto-isolated input, see A6
8	Trunk TX Inhibit*	I	J3-A25	TTL input
9	RF Relay Control Out (Aux I/O)	O	J1-B5, J2-B5	OCO, 200mA, 40V, active high
10	Ext PTT* Out (Aux I/O), Note 5	I	J1-A23, J2-A23, J3-A23	TTL input
11	RSSI	O	J1-A22, J2-A22, J3-A22	Typically 0.5Vdc for -120dBm to 3.5 Vdc for -40 dBm carrier. Variation with carrier level @ approximately 40mV/dBm.
12	GPI_10 (WCI) or GPO_4 (NS)	I/O	J1-A24, J2-A24	Caution: See Auxiliary I/O section for jumpering information
13	Spare 304	-	-	
14	Not Supported	O	J1-A19, J2-A19, J3-A19	
15	GND	-	Station ground	
16	GND	-	Station ground	
17	Disc RX Audio	O	J1-A16, J2-A16, J3-A16	Discriminator audio, flat response; 80mV to 400mV for 60% deviation
18	Cntrl 14.2 VDC	O	P8 pins 3, 4 (thru F2)	+14.2Vdc, Note 1
19	GND	-	Station ground	
20	5 VDC	O	P8 pins 7, 8	+5.1 ± 0.25 Vdc
21	Not Supported	O	J3-A12	
22	Spare 302	-	-	
23	Spare 324	-	-	
24	GPIO_0 (CNTR I/O)	I/O	J1-A9, J2-A9, J3-A17	TTL input/output
25	Spare 317	-	-	
26	Spare 901	-	-	
27	GND	-	Station ground	
28	Line 3+	I	J4-C12	Wireline input balanced, (+)
29	GPIO_1 (CNTR I/O)	I/O	J1-A4, J2-A4, J3-A13	TTL input/output
30	Line 3-	I	J4-A11	Wireline input balanced, (-)
31	GND	-	Station ground	
32	Cntrl 14.2 VDC	O	P8 pins 3, 4 (thru F2)	+14.2Vdc, Note 1
Note 5: Ext PTT signal output, taken from Ext PTT input. The output signal can be inverted, depending on jumper settings. See jumpers P2, P6, P9.				

Telephone Line Connections

Introduction

In conventional systems where the station is controlled by a remote console, or in wide area systems utilizing comparators, phone lines must be connected between the station and the remote equipment. The phone lines may carry analog voice, or encoded voice. Also carried on the phone lines are Tone Remote Control (type of remote control signalling). The following information defines the specifications for the phone lines, the location on the station backplane for phone line connections, and which of the four (4) wireline circuits to use for various system types.

Telephone Line Specifications

Most telephone companies recognize either “3002” or “Type 5” as designations to define phone line types and associated electrical specifications. Telephone lines meeting the specifications for either of these types are acceptable for use with the station. Table 9 shows the specifications for “3002” or “Type 5” phone line types.

Table 9. Type 5 and “3002” Phone Line Specifications

Parameter	Type 5 Specification	3002 Specification
Loss Deviation	±4.0 dB	±4.0 dB
C-Notched Noise	51 dBmCO	51 dBmCO
Attenuation Distortion: 504 to 2504 Hz 404 to 2804 Hz 304 to 3004 Hz	-2.0 to +8.0 dB -2.0 to +10.0 dB -3.0 to +12.0 dB	-2.0 to +8.0 dB -2.0 to +10.0 dB -3.0 to +12.0 dB
Signal To C-Notched Noise Ratio	≥24 dB	≥24 dB
Envelope Delay Distortion: 804 to 2604 Hz	1750 μsec	1750 μsec
Intermodulation Distortion: R2 R3	≥27 dB ≥32 dB	≥25 dB ≥30 dB
Phase Jitter: 20 to 300 Hz 4 to 300 Hz	≤10 Degrees ≤15 Degrees	≤25 Degrees ≤30 Degrees
Frequency Shift	±3 Hz	±5 Hz

Location of Telephone Line Connections

Wireline Connector

When 4-wire (2 line) telephone connections are required, Line 1 and Line 2 are provided through the 4-position wire wrap terminal connector. Table 10 provides a description of the Wireline connector line pair assignments.

Table 10. Wireline Connector Line Pair Assignments

Line Pair	Functionality
1 +/-	Tx wireline input for 4 wire configuration. Input level is programmable by RSS between 0 dBm to -50 dBm. Do not use this line pair for 2 wire wireline configuration.
2 +/-	Rx wireline output for 4 wire configuration. Output level is programmable between +7 dBm to -20 dBm for 100% deviation. Use this line pair for 2 wire wireline configuration.

Connector 4 has 8 holes:

- the round holes are for wire insertion, and
- the square holes are for insert release.

This wire-trap terminal connector accepts only 0.52 sq mm (20 AWG) to 0.2 sq mm (24 AWG); solid wire or stranded wire with a tin topcoat. Wires inserted into the connector should be stripped to length 9.53 mm (0.375 in).

As a removal release tool, use either:

- a stripped wire of any of above sizes, or
- the Wireline connector tool, part number 6600809D00.



Before applying excessive pullout force on the telephone connection wires, be sure to release wires properly.

System Connector

When 8-wire (4 line) telephone connections are required:

- Line 1 and Line 2 are provided through the 4-terminal Telephone connector.
- Line 3 and Line 4 are provided through the System connector.

The location of the Telephone and System connectors on the station rear panel is shown in Figure 9.

Table 4 describes the System connector pin assignments for Line Pairs 3 and 4.

System Type vs. Wireline Circuit

Table 11 shows which of the four (4) wireline circuits to use for various system types.

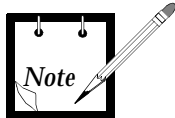

Stations equipped with a 4-wire Wireline Interface can support a single 4-wire or a single 2-wire telephone line connection.

Stations equipped with an 8-wire Wireline Interface can for example support a two 4-wire or a single 2-wire telephone line connection.

Table 11. System Types vs. Wireline Circuit Matrix

System Type	Line 1 (Note i)	Line 2 (Note i)	Line 3	Line 4
Conventional Local Area Analog	Console	Console	Not used	Not used
Conventional Wide Area Analog	Comparator or Console	Comparator	Not used	Not used
Trunked Local Area Clear, without CPI	CIT	CIT	Not used	Not used
Trunked Local Area Clear, with CPI	Console	Console	CIT	CIT
Trunked Wide Area Clear without CPI	Comparator	Comparator	Not used	Not used
Trunked Wide Area Clear, with CPI	Console	Console	Comparator	Comparator
Trunked AMSS Clear	Comparator	Comparator	Not used	Not used
Redundant Trunking Clear, Wide Area without CPI	Comparator	Comparator	Not used	Not used

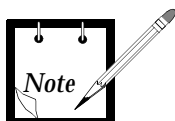

- i) For 4-wire systems, Line 1 is transmit audio (landline to station), and Line 2 is receive audio (station to landline). For 2-wire systems, Line 2 is transmit and receive audio.
- ii) A CPI is a Console Priority Interface.; used in Trunking systems. A CIT is a Central Interconnect Terminal; used in Trunking systems.
- iii) Transmit audio with respect to consoles, comparators, CIT, and DVM modems are outputs. Transmit audio with respect to stations is an input.
- iv) Receive audio with respect to consoles, comparators, CIT, and DVM modems are inputs. Receive audio with respect to stations is an output.

Station Maintenance Connections

Table 12 provides a description of the maintenance connections located on the front of the Station Control Module.

Table 12. Station Maintenance Connections on the SCM

Connector Name	Function	Details
5/10MHz External Reference Signal (J5603)	External Reference signal for internal system clock	5MHz or 10MHz external reference may be used. Select desired frequency through RSS. High impedance input. Minimum level is 1Vpp for either type of input. Maximum level should not exceed 3Vpp.
Service Speaker (P5601)	Output to Power Voice speaker	Adjustable between 0 to 500mV across 1Kohm @60% system deviation. Audio signal appears between pins 3 and 4 on the connector. Must use speaker type HSN1000 via adapter cable Part.No. 0185180U01.
RSS (P5600)	Serial Port	For connection to serial port of a computer via cable Part No. 3082056X02. The Radio Service Software (RSS) application is run on the computer.
Microphone (P5602)	Local Microphone Input	Use local microphone type GMN6147 or equivalent. Modulation sensitivity for 60% system deviation is typically 300mV. This microphone should be equipped with 3 control buttons for speaker volume control, Rx. monitor and Intercom control functions.

5

POST INSTALLATION CHECKLIST

After the station equipment has been mechanically installed and all electrical connections have been made, power may now be applied and the station checked for proper operation.

Applying Power

Before applying power to the station, make sure all boards are securely seated in the appropriate connectors on the backplane and that all rf cables are securely connected.

Turn ON the circuit breaker controlling the ac outlet that is supplying power to the station Power Supply Module, or switch on the DC-supply to a station with a DC-only Power Supply Module.

Changing Fuse

To replace the station fuse:

1. Turn off station power at source (e.g., ac breaker).
2. Remove fuse cover plate located on the backplane shield by unscrewing one M4 screw.
3. Pull defective fuse carefully with small needle nose pliers.
4. Replace new fuse (part # 6583049X16) carefully with small needle nose pliers.

**CAUTION**

For continued protection of the station against risk of fire, replace the fuse only with the same type and rating of fuse.

5. Restore power to the station.

Verifying Proper Operation

Operation of the station can be verified by:

- observing the state of the 4 LEDs located on the front panel
- listening to audible alarms, and
- exercising radio operation.



Some station components can become extremely hot during station operation. Turn off all power to the station, and wait until sufficiently cool before touching the station.

Front Panel LEDs

After turning the station power ON (or after a station reset), the 4 LEDs on the station front panel:

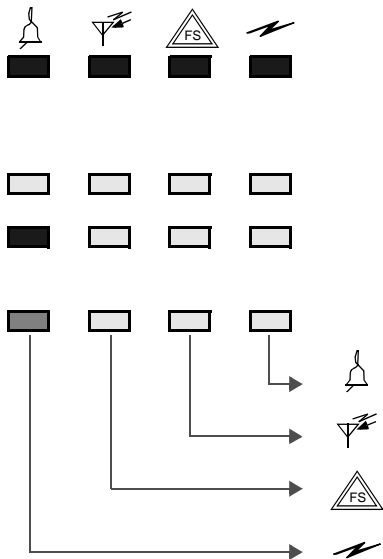

1. Are all lit for about 3 seconds to indicate that they are functional. The **Station Status** LED appears yellow since both the red and green LEDs of this bicolor indicator are lit at the same time.
2. All go off for about 15 seconds.
3. All stay off except for the **Station Status** LED which goes red for about 6 seconds.
4. Now indicate operational status of the station. The 4 LEDs indicate:
 - **PA Keyed** LED; green – station PA is keyed.
 - **FailSoft** LED; yellow – (if set up for trunking) station is not being controlled from the trunking central controller.
 - **Rx Active** LED; green – station is unscquelched.
 - **Station Status** LED; red/green – operational status of station.

Station Status LED

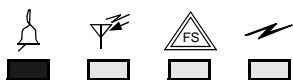

This two-color **Station Status** LED (i.e., red or green) indicates the following:

LED Color	LED State	Indicates that the...
Off	Off	5V power is not present
Red	On	Station is Not Operational – major failure
Red	Flashing	Station is Operational but Not Fully Functional – minor failure
Green	On	Station is Operating Normally
Red/Green	Alternately Flashing	Station is in Boot Mode
Green	Flashing	Station is in Service Mode

A major failure renders the station unusable. These failure could be caused by one of the following conditions:

- Rx or Tx synthesizer out of lock
- PA failure,
- Sharp (i.e., 10dB) rf power cutback,
- self test failure



A random flashing of the Station Status LED indicates major failure of the Station Control Module; since a control module reset turns the LEDs on.

A minor failure limits the functionality of the station. These failures could be caused by one of the following conditions:

- ac source power failure
- exciter or receiver analog metering voltage degradation
- wireline loopback failure
- invalid local channel selection

Boot mode is the mode the station is in during the loading of software into the station's Flash memory.

Service mode is the mode the station is in during normal maintenance and service periods. These modes include the following conditions:

- Intercom
- Access Disable
- Power Control Disable
- PL Disable
- Failsoft Disable
- Service PTT

The Radio Service Software (RSS) can be used to determine which failure or service modes are active.



Service mode indicates that the station is not fully functional.

RX Active LED

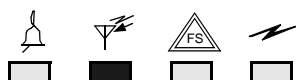

This **RX Active** LED indicates the following:

LED Color	LED State	Indicates that the...
Green	On	Receiver is active.

This LED is lit when receive activation criteria (user defined) are satisfied; i.e., the radio is unscquelched.

**FailSoft
LED**

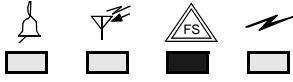

This **FailSoft** LED indicates the following:

LED Color	LED State	Indicates that the ...
Yellow	Flashing	station is in the Trunking system Failsoft mode.

This LED is lit when no activity is detected on the transmit data signal from the trunking central controller; the station is in Failsoft mode. This condition usually indicates a failed link to the trunking central controller.

**PA Keyed
LED**

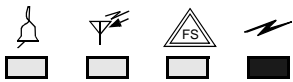

This **PA Keyed** LED indicates the following:

LED Color	LED State	Indicates that the ...
Green	On	PA is keyed.
Green	Flashing	PA is keyed, but operating with power cutback.

Listening For Audible Alarms

With a Service Speaker connected to the station (see Station Operation, Service Connections), any active audible alarms can be heard.

Alarm	Sound	Indicates that ...
AC Fail	a single short beep	a station configured with DC-revert has detected an AC power failure.
PA Fail	two short beeps	the station has been keyed, and the Power Amplifier has failed.

The audible alarms are repeated every 10 seconds. If more than one alarm is active, they are offset by 2 seconds.

Exercising Radio Operation

Operation of the station radio can be verified by exercising the radio's two-way operation. This may be carried out when an external speaker and microphone are connected to the Station Control Module (SCM).

The kit # for the speaker is HSN1000. The external speaker requires an adaptor cable, part # 0185180U01.



Using a speaker other than the recommended HSN1000 may result in the station blowing a fuse.

The kit number for the microphone is GMN6147B.

6

OPTIMIZATION

After the station and ancillary equipment have been mechanically installed, properly cabled, and power applied, the equipment must then be optimized; that is, before placing the station in operation. Optimizing is performed through the Radio Service Software (RSS), kit number RVN4148.

After the station is operational, the station's codeplug data must be copied to a PC- compatible computer.



In order to program an MTR2000 station for Trunking operation, kit number RVN4148C (or later) of the RSS must be used. The current version is available through the U.S. and Canada Americas Aftermarket Division (AAD).

Optimizing Tasks

Optimization involves the following tasks:

1. Reading the station codeplug from the station (this ensures a match between the station serial number (resident in the codeplug) and the serial number (part of the customized station codeplug data) that is written back to the station (see task 5).
2. Customizing the station codeplug and saving the data to the station
3. Aligning the station for:
 - Rx Wireline
 - Tx Wireline
 - Receiver RSSI calibration (option)
 - Receiver Squelch Adjust
4. Performing post-optimization procedures.
5. Writing the customized codeplug to the station codeplug.

For details on these tasks, refer to the *Optimizing a New Installation* topic of the Radio Service Software (RSS) Online Help.

Copying Station Codeplug Data To a PC-compatible Computer



A copy of each station's codeplug data must be made on an IBM-PC compatible computer. This is done through the Radio Service Software (RSS). See the RSS Startup Manual, 68P81096E15.

7

INSTALLING STATION HARDWARE OPTIONS

When a station is ordered with an Antenna Relay or External Preselector option, the respective module is attached to the station when delivered.

When a station is ordered with an External Double Circulator option, this circulator is provided in a peripheral tray.

In the case where an option is later added to the station, it can be installed according to the information provided in the Ancillary Equipment sections of the appropriate Instruction manual. Also refer to the Troubleshooting section for information on tuning the External Preselector.



STATION OPERATION

1

DESCRIPTION

This section describes the LED indicators and connectors provided on the station.

The set of LEDs indicate the operational status of the station.

There are two sets of connectors for devices external to the station:

- One set connects to external devices to enable full operation of the station. These are located at the back of the station.
- Another set connects to external devices for servicing the station. These are located on the Station Control Module.

LED Indicators

A set of 4 LEDs is located on the station front panel. The position of the 4 LEDs on the front panel is shown in Figure 1. These LEDs indicate the status of the station during normal operation.

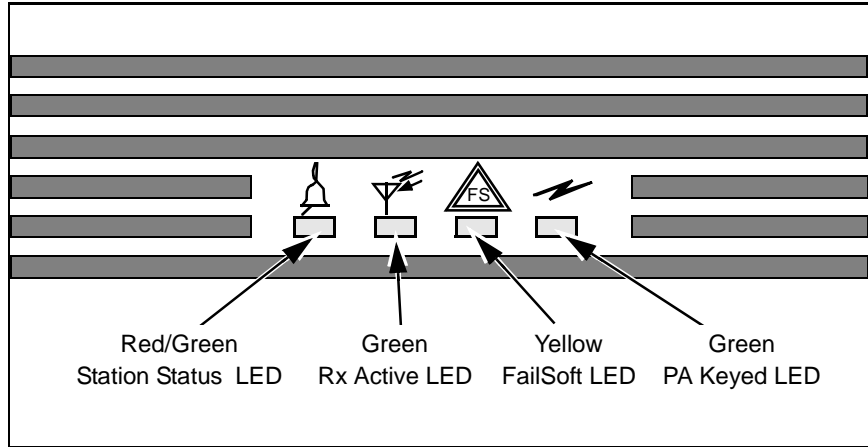





Figure 1. Front Panel LEDs

For further information on the states indicated by these LEDs, refer to the INSTALLATION section, Post Installation Checklist, Verifying Proper Operation.

	Function	Color	Indicates ...
	Station Status	red / green	... operational status of station.
	Rx Active	green	... that the station Rx activation criteria are satisfied. This could be: <ul style="list-style-type: none"> - RF carrier only, - PL/DPL only, or - RF carrier plus PL/DPL.
	FailSoft	yellow	... (if set up for trunking) that the station is not being controlled from the trunking central controller.
	PA Keyed	green	... that station PA is keyed.

External Device Connections

Refer to INSTALLATION, Electrical Connections for the position of the station external connectors and line cord, located on the back panel.

A BNC connector on the front of the SCM allows the station to be connected to a 5 MHz or 10 MHz external reference signal.

Figure 2 shows the position of the BNC connector on the SCM.

Service Connections

Service ports and LEDs are located on the front of the Station Control Module (SCM).

Figure 2 shows the position of the connectors on the SCM.

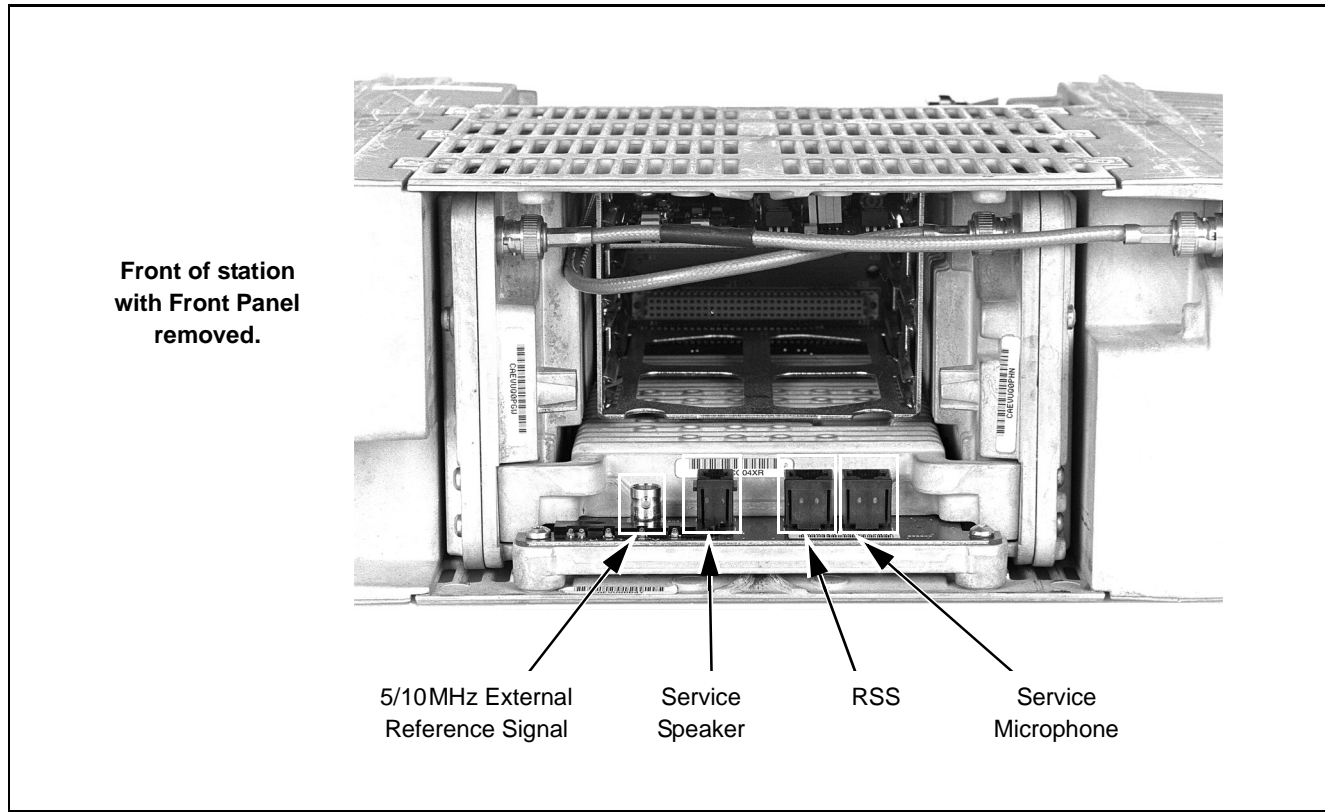

Figure 2. SCM Connectors

The service ports include connectors for:

- 5/10 MHz External Reference Signal
- Service Speaker:
connects between the telephone connector on the Station Control Module and an external speaker/amplifier (with a 6 pin molex connector) via an adaptor cable; part number 0185180U01.
- RSS:
connects between the telephone connector on the Station Control Module and the DB9 connector on a PC. A DB25 connector can also be used to connect to the PC, when used with a DB25-DB9 adaptor.
- Service Microphone:
connects between the telephone connector on the Station Control Module and a service microphone.